

July 2023

EZH and EZHSO Series Pressure Reducing Regulators

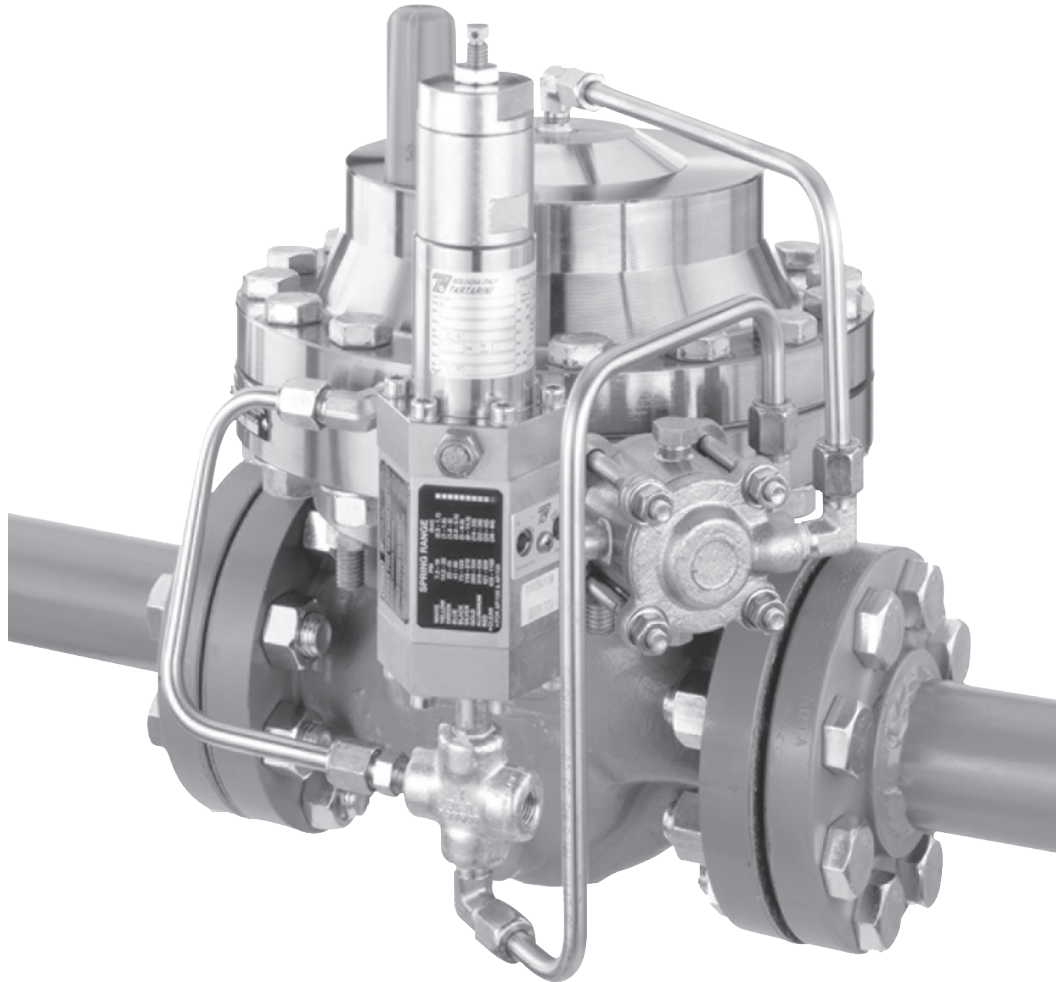

Figure 1. Type EZH Pressure Reducing Regulator

EZH and EZHSO Series

Specifications

The Specifications section lists the specifications for the EZH and EZHSO Series pressure reducing regulators. Factory specification is stamped on the nameplate fastened on the regulator at the factory.

Available Configurations

Type EZH: Spring-to-close pilot-operated pressure reducing regulator for low to high outlet pressure

Type EZHSO: Spring-to-open pilot-operated pressure reducing regulator for low to high outlet pressure

Type EZHOSX: Type EZH with a Type OS2 slam-shut device for overpressure (OPSO), overpressure and underpressure (OPSO/UPSO) or dual overpressure (OPSO/OPSO) protection

Body Sizes, End Connection Styles and Pressure Ratings⁽¹⁾

See Table 1

Maximum Allowable Pressures⁽¹⁾

Inlet Pressure: 1500 psig / 103 bar

Outlet (Casing) Pressure: 1500 psig / 103 bar

Emergency Casing Pressure: 1500 psig / 103 bar

Maximum Operating Differential Pressures⁽¹⁾⁽³⁾

Main Valve: 1500 psid / 103 bar d

Pilot: *Between loading pressure in pilot and loading sense pressure:* 1233 psid / 85.0 bar d

Minimum Differential Pressures⁽¹⁾

See Table 3

Outlet Pressure Ranges

See Table 2

Flow and Sizing Coefficients

See Tables 7 through 16

Flow Capacities

See Tables 17 and 18

Pilot and Filter Regulator Flow Coefficients

Type PRX Pilot: C_g : 10.5; C_v : 0.36; C_f : 29

Type SA/2 Filter Regulator: C_g : 4.9

Pressure Registration

External

Pilot Connections

1/4 NPT

Process Temperature Capabilities⁽¹⁾

Nitrile (NBR) Version: -20 to 180°F / -29 to 82°C

Fluorocarbon (FKM) Version: 0 to 180°F / -18 to 82°C⁽²⁾

Process Temperature Capabilities⁽¹⁾(continued)

Polyurethane (PU) Version

NPS 1, 2, 6, 8, 12 X 6 / DN 25, 50, 150, 200,

300 X 150 Sizes: -22 to 180°F / -30 to 82°C

NPS 3 to 4 / DN 80 to 100 Sizes: -4 to 180°F / -20 to 82°C

Options

- Travel Indicator
- Whisper Trim™ Cage
- Relief Size-reduction Trim

Construction Materials

Main Valve

Main Valve Body

Types EZH and EZHSO: WCC Steel

Type EZHOSX: LCC Steel

Intermediate Flange and Actuator Casings: Steel, ASTM A350 LF2

Diaphragm Plates: Steel, ASTM A105

Diaphragm: Nitrile (NBR) with PVC coating

O-ring: Fluorocarbon (FKM)

Disk: Nitrile (NBR), Fluorocarbon (FKM) or Polyurethane (PU)

PRX Series Pilots

Body: Steel, ASTM 105

Trim: Stainless steel

Elastomers: Nitrile (NBR) or Fluorocarbon (FKM)

Disk: Polyurethane (PU) or Fluorocarbon (FKM)

Type SA/2 Pilot Supply Filter Regulator

Body: Steel

Diaphragm: Nitrile (NBR) with PVC coating

O-ring/Disk: Nitrile (NBR) or Fluorocarbon (FKM)

Type OS2 Slam-Shut Device

Mechanism Box: Aluminum alloy

First and Second Stage Mechanism: WCC Steel

Diaphragm: Nitrile (NBR)

Bellows: 316 Stainless steel

Approximate Weights

See Table 20

1. The pressure/temperature limits in this Bulletin and any applicable standard or code limitation should not be exceeded.

2. Types PRX and SA/2 Fluorocarbon (FKM) elastomer is limited to 0°F / -18°C.

3. Maximum Operating Differential Pressure is 1400 psid / 96.5 bar d for NPS 1 / DN 25 Type EZHSO.

Features

- **No Gas Emissions**—Eliminates nuisance and wasteful bleed gas to atmosphere by utilizing a self-contained control system, which bleeds 100% of the gas to the downstream system.
- **Bubble-Tight Shutoff**—A knife-edged metal plug and soft seat provide bubble tight shutoff for use in applications where positive shutoff is required such as dead-end systems.
- **Long Life in Severe Service Applications**—The metal plug design deflects particles and debris away from the soft-seat, which gives excellent particle erosion resistance, prolonging service life.
- **Failure Mode Options**—The Type EZHSO spring-to-open design can be utilized to maximize uptime while the Type EZH spring-to-close design can be utilized to protect downstream assets. For many customers, combining the two technologies with a Type EZHSO worker and Type EZH monitor incorporates the best of both worlds.
- **Precise Pressure Control**—Provides stable and accurate downstream pressure control regardless of inlet pressure variations or demand changes.
- **Quiet Operation**—The Whisper Trim™ Cage option reduces noise by up to 8 dBA at the source, eliminating the need for expensive path treatments such as insulation, buried valves and enclosures which only mask noise.
- **Full Pressure Rating**—The equal inlet and outlet pressure rating of 1500 psig / 103 bar, which allows easier selection and requires no special startup or shutdown procedures.
- **Integral Slam Shut Configurations**—Type EZHOSX interrupts gas service during an overpressure or underpressure condition.
- **Easy In-Line Maintenance**—Top entry design enables easier maintenance. Trim parts can be inspected, cleaned and replaced without removing the body from the pipeline. In addition, the NPS 4 / DN 100 and larger sizes are designed for craneless disk maintenance, utilizing an innovative trim removal design.
- **High Turn Down Capability**—The oversized diaphragm and unique piloting system allow for high turn down, which will provide superior pressure control in systems with large variations in downstream flow demand.
- **Travel Indicator**—Simplifies in-service inspection and system troubleshooting.
- **Main Diaphragm**—The main diaphragm is Nitrile (NBR) reinforced with fabric and coated with PVC, which protects and extends the service life in applications with aromatic hydrocarbons.
- **Common Body Platform**—The EZH and EZHSO Series use the same standard Fisher™ E-Body which is also used in the Types EZR and EZL pressure reducing regulators and Types EZ, ES, ED and ET pressure reducing control valves. This allows easy conversion from one product to another without the need to remove the E-Body from the pipeline.
- **Full Usable Capacity**—Fisher brand regulators are laboratory tested. 100% of the published flow capacity can be used with confidence.
- **Disk Design**—The EZH and EZHSO Series offer disks for the main body made from Nitrile (NBR), Fluorocarbon (FKM) and Polyurethane (PU). Polyurethane (PU) provides better abrasion resistance properties and a high durometer rating to extend the working life of the disk in difficult applications such as high pressure drop and low flow.
- **Hydrogen Ready**—Products have been evaluated for material compatibility, potential leakage and permeation and susceptibility to embrittlement for Hydrogen applications. Based on an extensive evaluation and testing program, EZH Series configurations are available for use in Hydrogen applications.

Introduction

Types EZH (Spring-to-Close version) and EZHSO (Spring-to-Open version) regulators are accurate pilot-operated, pressure-balanced, soft-seated regulators. They are designed for use in high pressure natural gas transmission, city gate stations, large capacity distribution systems and power plant feeds. They provide smooth and reliable operation, tight shutoff and long life.

For underpressure or overpressure protection, the Type EZHOSX is available with an integral slam-shut device to completely shut off the flow of gas to the downstream system.

EZH and EZHSO Series

Table 1. Main Valve Body Sizes, End Connection Styles and Body Ratings

MAIN VALVE BODY SIZE		MAIN VALVE BODY MATERIAL	END CONNECTION STYLE	STRUCTURAL DESIGN RATING	
NPS	DN			psig	bar
1 and 2	25 and 50	LCC or WCC Steel	NPT or SWE	1500	103
1, 2, 3, 4, 6, 12 X 6 and 8	25, 50, 80, 100, 150, 300 X 150 and 200		CL150 RF	290	20.0
			CL300 RF	750	51.7
			CL600 RF or BWE	1500	103

Table 2. Outlet Pressure Ranges

TYPE	OUTLET PRESSURE RANGE		AC (ACCURACY CLASS)		PILOT CONTROL SPRING INFORMATION					
	psig	bar	EZH Series	EZHSO Series	Spring Color	Part Number	Wire Diameter		Free Length	
							In.	cm	In.	cm
PRX/120 PRX/125 PRX/131	14.5 to 26 23 to 44 41 to 80 73 to 123	1.00 to 1.8 1.6 to 3.0 2.8 to 5.5 5.0 to 8.5	2.5%	2.5%	Yellow Green Blue Black	M0255240X12 M0255230X12 M0255180X12 M0255220X12	0.110 0.126 0.138 0.157	0.28 0.32 0.35 0.40	2.16	5.49
	116 to 210 203 to 334 319 to 435	8.0 to 14.5 14.0 to 23.0 22.0 to 30.0	1%	2.5%	Silver Gold Aluminum	M0255210X12 M0255200X12 M0255860X12	0.177 0.197 0.236	0.45 0.50 0.60	2.16 2.00 2.00	5.49 5.10 5.10
PRX/120-AP PRX/125-AP PRX/131-AP	435 to 1160	30.0 to 80.0	1%	2.5%	Clear	M0273790X12	0.335	0.85	3.93	10.0

Table 3. Minimum Differential Pressures

TYPE	MAIN VALVE BODY SIZE		MINIMUM DIFFERENTIAL			
	NPS	DN	For 90% Capacity		For 100% Capacity	
			psid	bar d	psid	bar d
EZH	1	25	15.2	1.1	15.7	1.1
	2	50	12.0	0.83	13.8	0.95
	3	80	10.6	0.73	12.8	0.88
	4	100	15.8	1.1	16.4	1.1
	6, 8 and 12 X 6	150, 200 and 300 X 600	----	----	14.0 for standard version 3.0 ⁽¹⁾ for low differential version	0.98 for standard version 0.21 ⁽¹⁾ for low differential version
EZHSO	1	25	55	3.8	55	3.8
	2	50	55	3.8	55	3.8
	3	80	55	3.8	55	3.8
	4	100	----	----	25.6	1.8
	6, 8 and 12 X 6	150, 200 and 300 X 600	----	----	14.0	0.97

1. Low differential version has a maximum inlet pressure rating of 290 psi / 20.0 bar and process temperature limitation of -4 to 180°F / -20 to 82°C.

Pilot Descriptions

The EZH and EZHSO Series pressure reducing regulators include a PRX Series pilot mounted on the main valve.

Type PRX/120: Outlet pressure range of 14.5 to 435 psig / 1.00 to 30.0 bar. The Type PRX/120 can be used as the pilot on single stage pressure reducing regulators, as the monitor or working pilot in wide-open monitor systems or as the working pilots in working monitor systems.

Type PRX/120-AP: Outlet pressure range of 435 to 1160 psig / 30.0 to 80.0 bar. The Type PRX/120-AP can be used as the pilot on single stage pressure reducing regulators, as the monitor or working pilot in wide-open monitor systems or as the working pilots in working monitor systems.

Type PRX/125: Identical to the Type PRX/120 except the restriction screw is removed. The Type PRX/125 can only be used as the monitor override pilot on working monitor applications.

Type PRX/125-AP: Identical to the Type PRX/120-AP except the restriction screw is removed. The Type PRX/125-AP can only be used as the monitor override pilot on working monitor applications.

Type PRX/131: Set pressure range of 14.5 to 435 psig / 1.00 to 30.0 bar. The Type PRX/131 is used as a booster or quick dump pilot to increase main valve closing speed with another PRX Series pilot on a single stage pressure reducing regulator or with the monitor pilot on the monitor regulator in wide-open monitor systems.

Pilot Supply Filter Regulator

The Type SA/2 pilot supply filter regulator provides a constant supply pressure to the PRX Series pilot that is approximately 45 psig / 3.1 bar over set pressure. The Type SA/2 has an integral 5-micron filter.

Principle of Operation

EZH Series - Spring-To-Close Version

The pilot-operated EZH Series (Spring-to-Close version) will fail in close position in the case of main valve diaphragm failure or lack of supply pressure to the pilot (see Table 4 for the Failure Mode Analysis).

The EZH Series (Figure 2) uses inlet pressure which is reduced through pilot operation to load the regulator actuator diaphragm (lower chamber). Outlet pressure is supplied to the regulator actuator diaphragm (upper chamber). This pressure assists the main spring that tends to close the regulator and opposes loading pressure in the actuator. Outlet pressure also opposes the pilot control spring.

The PRX Series pilot is supplied with pressure coming from pre-regulator Type SA/2, which reduces inlet pressure to the value of outlet pressure plus approximately 45 psi / 3.1 bar.

When outlet pressure drops below the setting of the pilot control spring, pilot control spring force on the pilot lower diaphragm opens the pilot valve disk, providing additional loading pressure to the lower chamber of the regulator actuator diaphragm. This diaphragm loading pressure opens the main valve disk, supplying the required flow to the downstream system. Any excess loading pressure in the lower chamber of the actuator diaphragm and pilot escapes downstream through the bleed restriction in the pilot.

When the gas demand in the downstream system has been satisfied, the outlet pressure increases. When outlet pressure increases over the setting of the pilot spring, the pilot valve disk will be closed, reducing loading pressure to the lower chamber of the regulator actuator diaphragm; the pressure in the upper case and the main spring will force the regulator to close. The excess loading pressure acting under the regulator actuator diaphragm and pilot bleeds to the downstream system through a bleed restriction in the pilot.

A check valve, set at 75 psi / 5.2 bar, is installed between outlet pressure and loading pressure impulse lines on the NPS 4 / DN 100 and larger sizes; this valve is designed to protect the main valve diaphragm assembly from excessive differential pressure during startup if incorrect start up procedures are used. Do not exceed 75 psi / 5.2 bar differential pressure between the outlet pressure and loading pressure impulse lines.

EZH and EZHSO Series

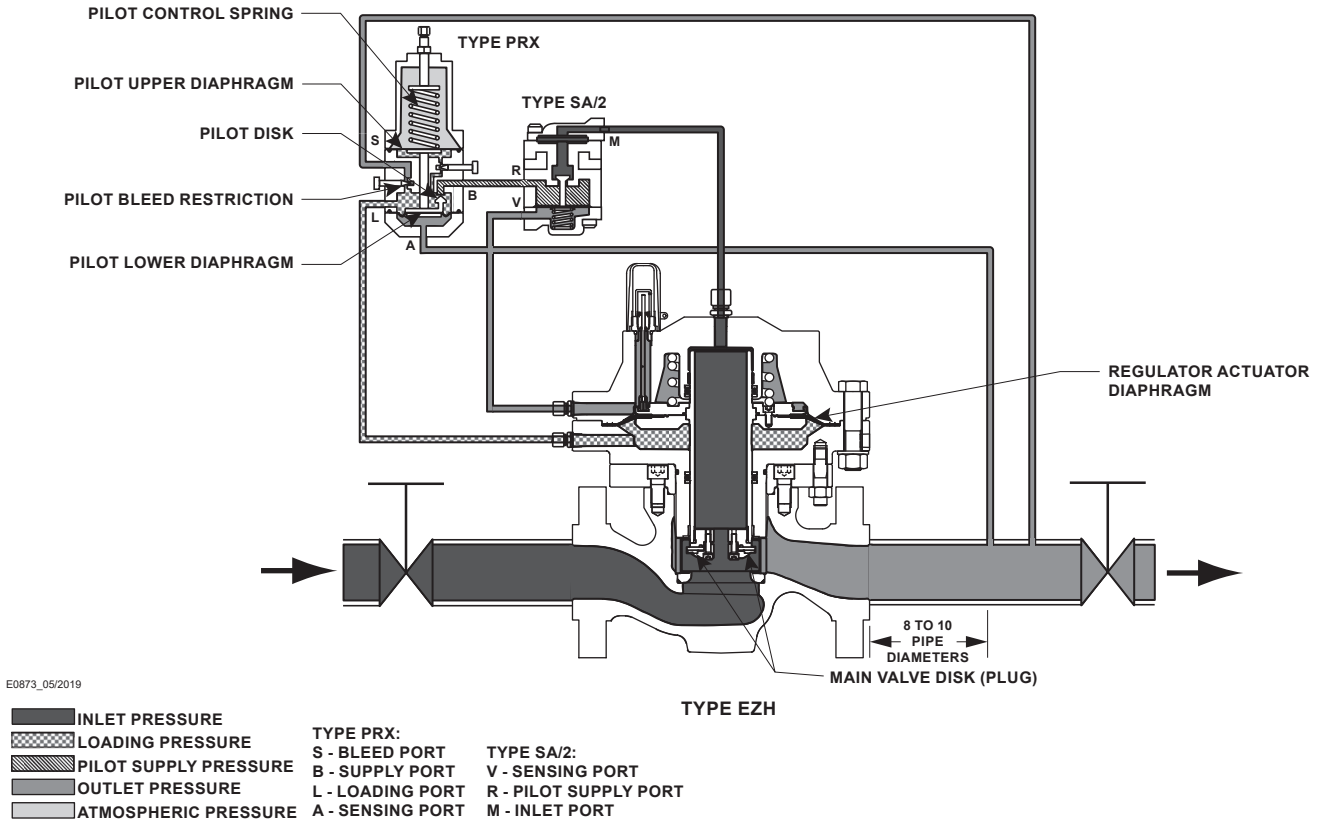

Figure 2. Type EZH (Spring-to-Close Version) Operational Schematic

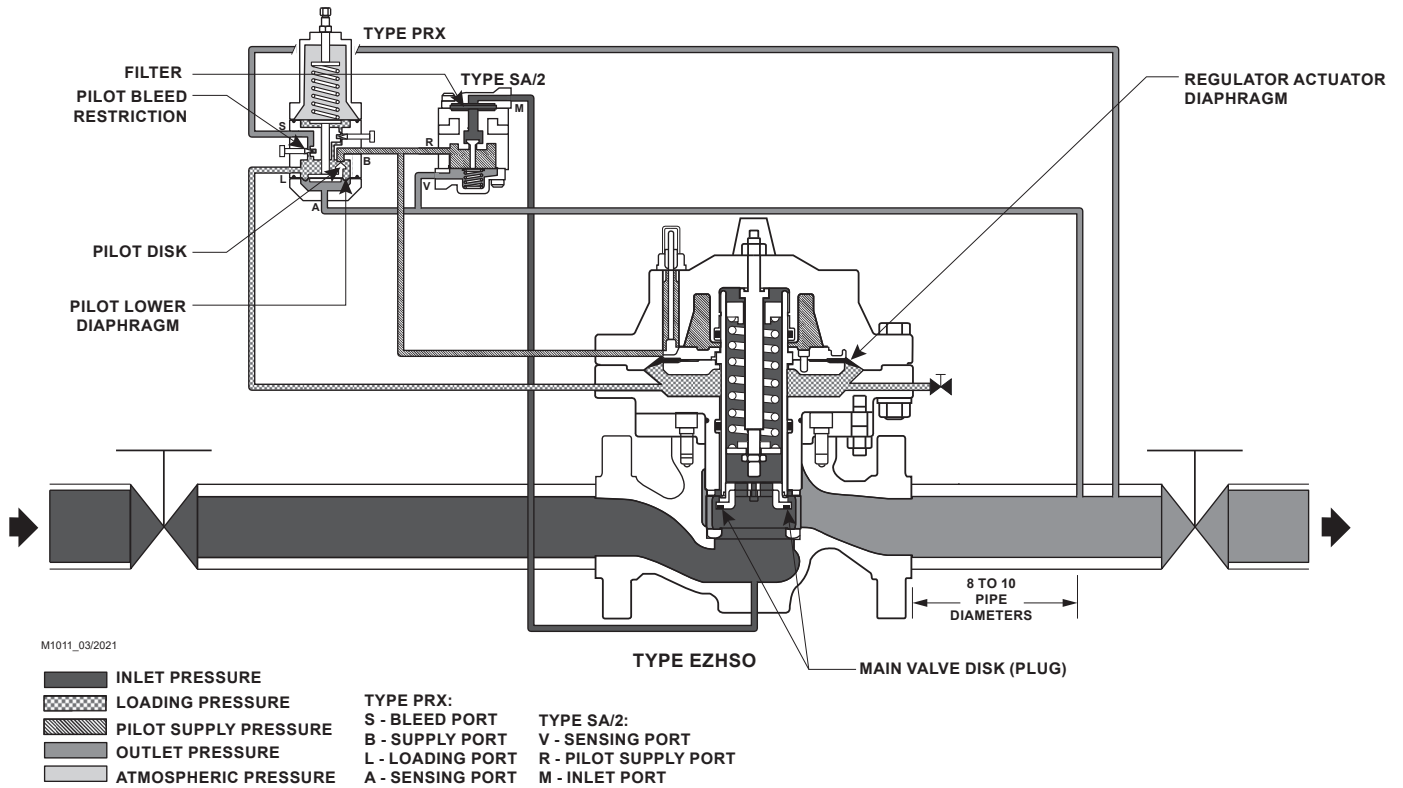

Figure 3. Type EZHSO (Spring-to-Open Version) Operational Schematic

Table 4. Failure Mode Analysis

PART NAME	CONDITION	CAUSE	EFFECT	REGULATOR REACTION MODE	
				Type EZH	Type EZHSO
Filter	Filter blocked / Clogged	Debris or aromatics present in the gas	Decrease of supply pressure gives decrease of loading pressure	Close	Open
Pilot disk	Pilot cannot be closed	Debris or aromatics present, Sour gas	Increase loading pressure	Open	Open
Pilot lower diaphragm	Pilot cannot control	Debris or aromatics present, Sour gas	Decrease loading pressure	Close	Open
Pilot upper diaphragm	Pilot cannot feed the regulator	Debris or aromatics present, Sour gas	Decrease loading pressure	Close	Open
Regulator diaphragm	Not proper performance of the loading pressure chamber	Debris or aromatics present, Sour gas	Balancing of Pressures and charge or discharge of the loading pressure chamber	Close	Open
Pilot	Frozen pilot, Type SA/2 not working	Moisture in the gas, high pressure drop	Type SA/2 loading upper casing of regulator, Pilot not supplying loading pressure to lower casing	Close	Close

EZHSO Series - Spring-To-Open Version

The pilot-operated EZHSO Series (Spring-to-Open Version) will fail in open position in the case of main valve diaphragm failure or lack of supply pressure to the pilot (see Table 4 for the Failure Mode Analysis).

The EZHSO Series (Figure 3) uses inlet pressure, which is reduced through pilot operation to load the regulator actuator diaphragm (lower chamber). Pilot supply pressure is provided to the regulator actuator diaphragm (upper chamber). This pressure on the upper chamber of the regulator actuator diaphragm opposes the main spring force that tends to open the regulator. Outlet pressure opposes the pilot control spring.

The PRX Series pilot is supplied with pressure coming from pre-regulator Type SA/2, which reduces inlet pressure to the value of outlet pressure plus approximately 45 psi / 3.1 bar.

When outlet pressure drops below the setting of the pilot control spring, pilot control spring force on the pilot diaphragm opens the pilot valve disk, providing additional loading pressure to the lower chamber of the regulator actuator diaphragm. This diaphragm

loading pressure opens the main valve disk, supplying the required flow to the downstream system. Any excess loading pressure in the lower chamber of the regulator actuator diaphragm and pilot escapes downstream through the bleed restriction in the pilot.

When the gas demand in the downstream system has been satisfied, the outlet pressure increases. When outlet pressure increases over the setting of the pilot spring, the pilot valve disk will be closed, reducing loading pressure to the lower chamber of the regulator actuator diaphragm; the pressure in the upper chamber will force the regulator to close. The excess loading pressure acting under the regulator actuator diaphragm and pilot bleeds to the downstream system through a bleed restriction in the pilot.

A check valve, set at 75 psi / 5.2 bar, is installed between inlet pressure to upper actuator casing and loading pressure impulse lines on the NPS 4 / DN 100 and larger sizes; this valve is designed to protect the main valve diaphragm assembly from excessive differential pressure during incorrect start-up procedures.

EZH and EZHSO Series

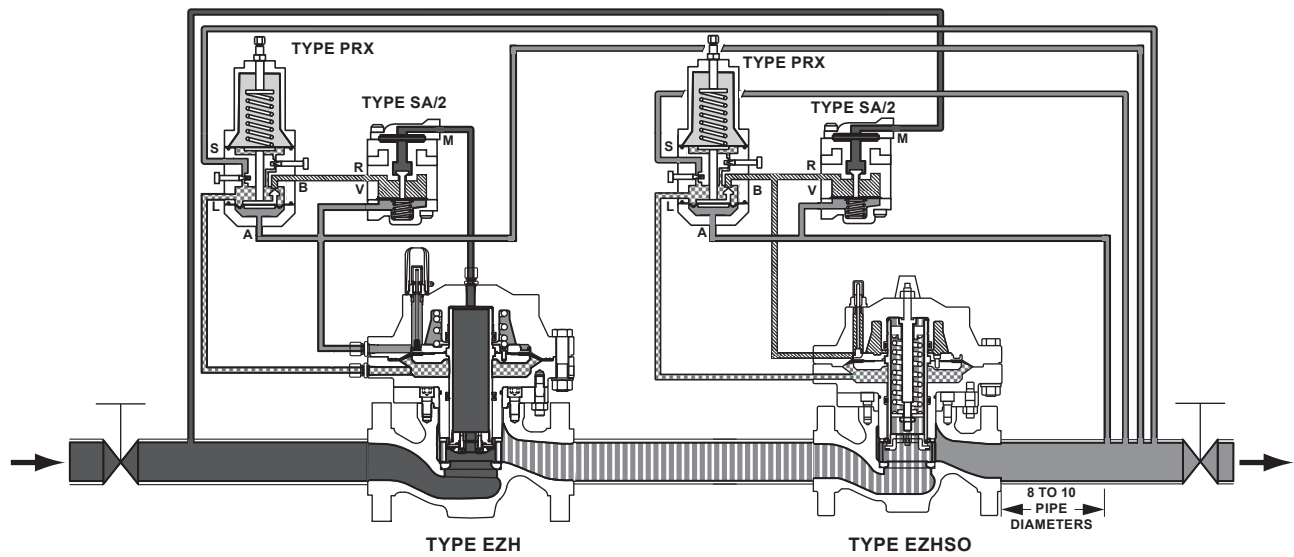

M1164_05/2019

- | | | | |
|--|-----------------------|------------------|-----------------------|
| | INLET PRESSURE | | |
| | LOADING PRESSURE | | |
| | INTERMEDIATE PRESSURE | TYPE PRX: | |
| | PILOT SUPPLY PRESSURE | S - BLEED PORT | TYPE SA/2: |
| | OUTLET PRESSURE | B - SUPPLY PORT | V - SENSING PORT |
| | ATMOSPHERIC PRESSURE | L - LOADING PORT | R - PILOT SUPPLY PORT |
| | | A - SENSING PORT | M - INLET PORT |

Figure 4. Wide-Open Monitoring System Operational Schematic

Monitoring Systems

Monitoring regulation is overpressure protection by containment, therefore, there is no relief valve to vent to the atmosphere. When the working regulator fails to control the pressure, a monitor regulator installed in series, sensing the downstream pressure, goes into operation to maintain the downstream pressure at a slightly higher value than normal set pressure. During an overpressure situation, monitoring keeps the customer on line. Also, testing is relatively easy. To perform a periodic test on a monitoring regulator, increase the outlet set pressure of the working regulator and watch the outlet pressure gauge to determine if the monitoring regulator takes over at the appropriate outlet pressure.

Wide-Open Monitoring Systems (Figure 4)

There are two types of wide-open monitoring systems: upstream and downstream. The difference between upstream and downstream monitoring is that the functions of the regulators are reversed. Systems can be changed from upstream to downstream monitoring and vice-versa, by simply reversing the setpoints of the two regulators. The decision to use either an upstream or downstream monitoring system is largely a matter of personal preference or company policy.

In normal operation of a wide-open configuration, the working regulator controls the system's outlet pressure. With a higher outlet pressure setting, the monitor regulator senses a pressure lower than its setpoint and tries to increase outlet pressure by going wide-open. If the working regulator fails, the monitoring regulator assumes control and holds the outlet pressure at its outlet pressure setting.

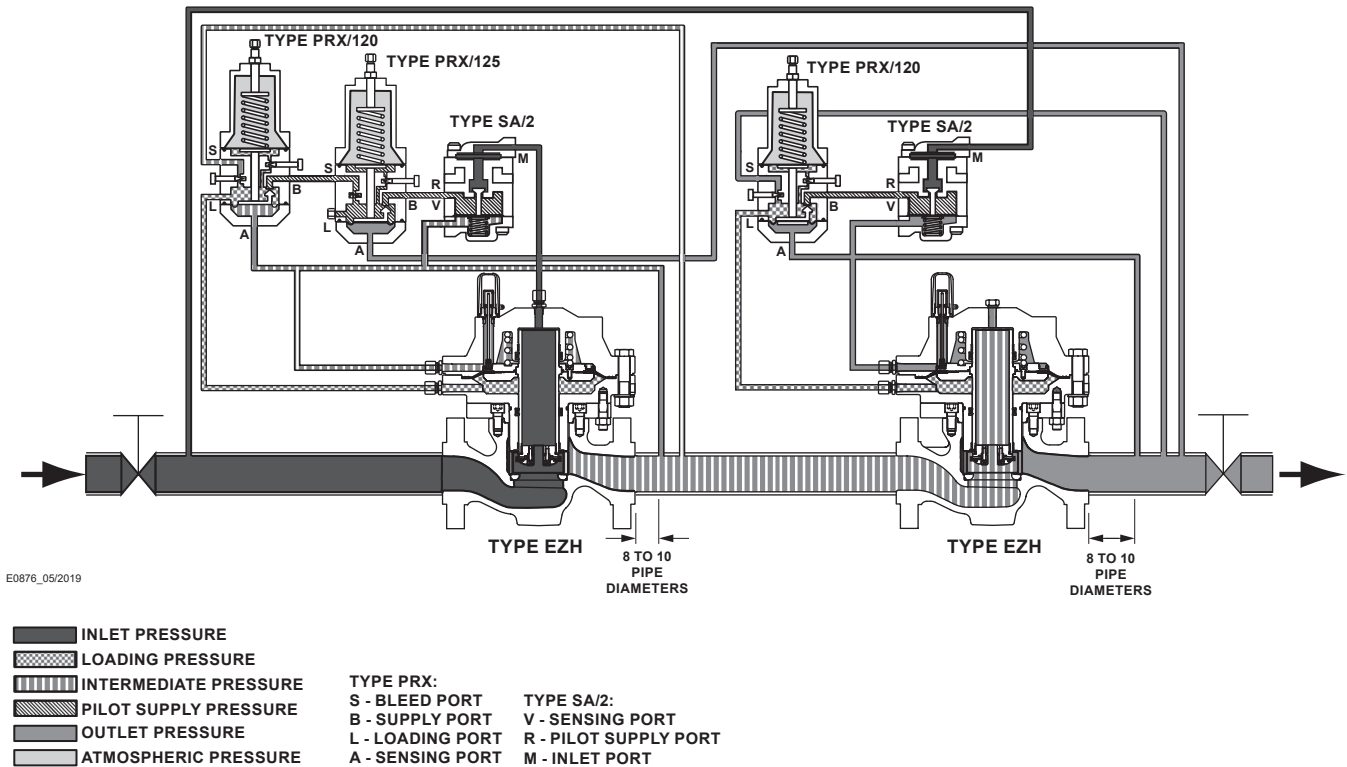

E0876_05/2019

Figure 5. Working Monitoring System Operational Schematic

Figure 4 shows an upstream wide-open monitor Type EZH (fail-to-close) and a downstream active regulator Type EZHSO (fail-to-open). In this installation, if the Type EZHSO regulator no longer controls downstream pressure, it will remain open, letting the Type EZH monitor regulator take control of the downstream pressure. Should the Type EZH fail, the monitor regulator will close and protect the downstream system from overpressure condition.

Working Monitoring Regulators (Figure 5)

In a working monitoring system, the upstream regulator requires two pilots and it is always the monitoring regulator. The additional pilot permits the monitoring regulator to act as a series regulator to control an intermediate pressure during normal operation. In this way, both units are always operating and can be easily checked for proper operation.

In normal operation, the working regulator controls the outlet pressure of the system. The monitoring regulator's working pilot controls the intermediate pressure and the monitoring pilot senses the system's outlet pressure. If the working regulator fails, the monitoring pilot will sense the increase in outlet pressure and take control.

Working monitor installations require an EZH or EZHSO Series main valve with a Type PRX/120 or PRX/120-AP working pilot and a Type PRX/125 or PRX/125-AP monitoring pilot for the upstream regulator and an EZH or EZHSO Series with the appropriate Type PRX/120 or PRX/120-AP pilot for the downstream regulator.

EZH and EZHSO Series

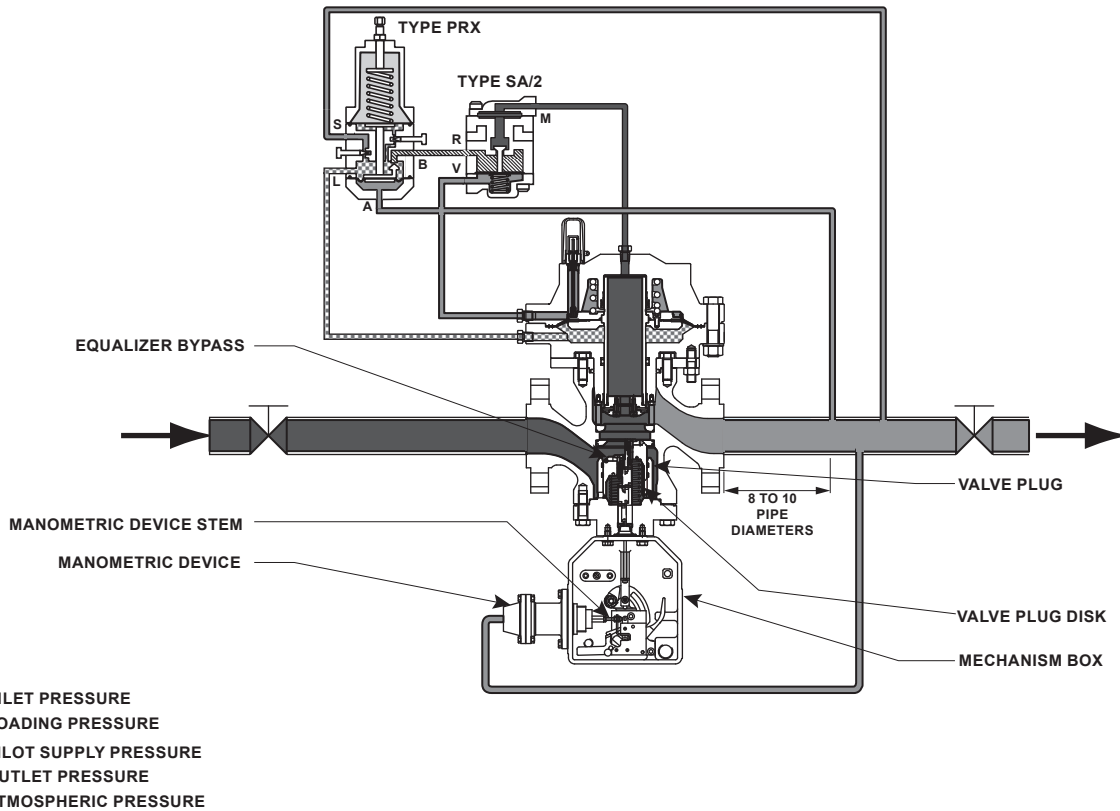

E0939_05/2019

Figure 6. Type EZHOSX Operational Schematic

Overpressure Protection

Overpressuring any portion of a regulator or associated equipment may cause personal injury, leakage or property damage due to bursting of pressure-containing parts or explosion of accumulated gas. Provide appropriate pressure relieving or pressure limiting devices to ensure that the limits in the Specifications section are not exceeded. Regulator operation within ratings does not prevent the possibility of damage from external sources or from debris in the pipeline. Common methods of external overpressure protection include relief valves, monitoring regulators, shutoff devices and series regulation.

The Type EZHOSX (Figure 6) regulator relies on the integrated slam-shut device for overpressure (OPSO), overpressure and underpressure (OPSO/UPS0) or dual overpressure (OPSO/OPSO) protection. In the event that outlet pressure rises above or falls below the pressure setting, slam shut will completely shut off the flow of gas to the downstream system.

Noise Abatement Trim

Whisper Trim™ cage provides effective attenuation of aerodynamic noise in gas applications involving high pressure drop ratios. Aerodynamic noise is generated by the turbulence created in the flow of gas as the fluid passes through the port. To achieve effective noise attenuation, a Whisper Trim cage utilizes multiple orifices of special shape, size and spacing. These orifices break up turbulent fluid streams, reducing noise-producing interactions.

EZH and EZHSO Series regulators offer an optional Whisper Trim Cage to reduce noise by up to 8 dBA.

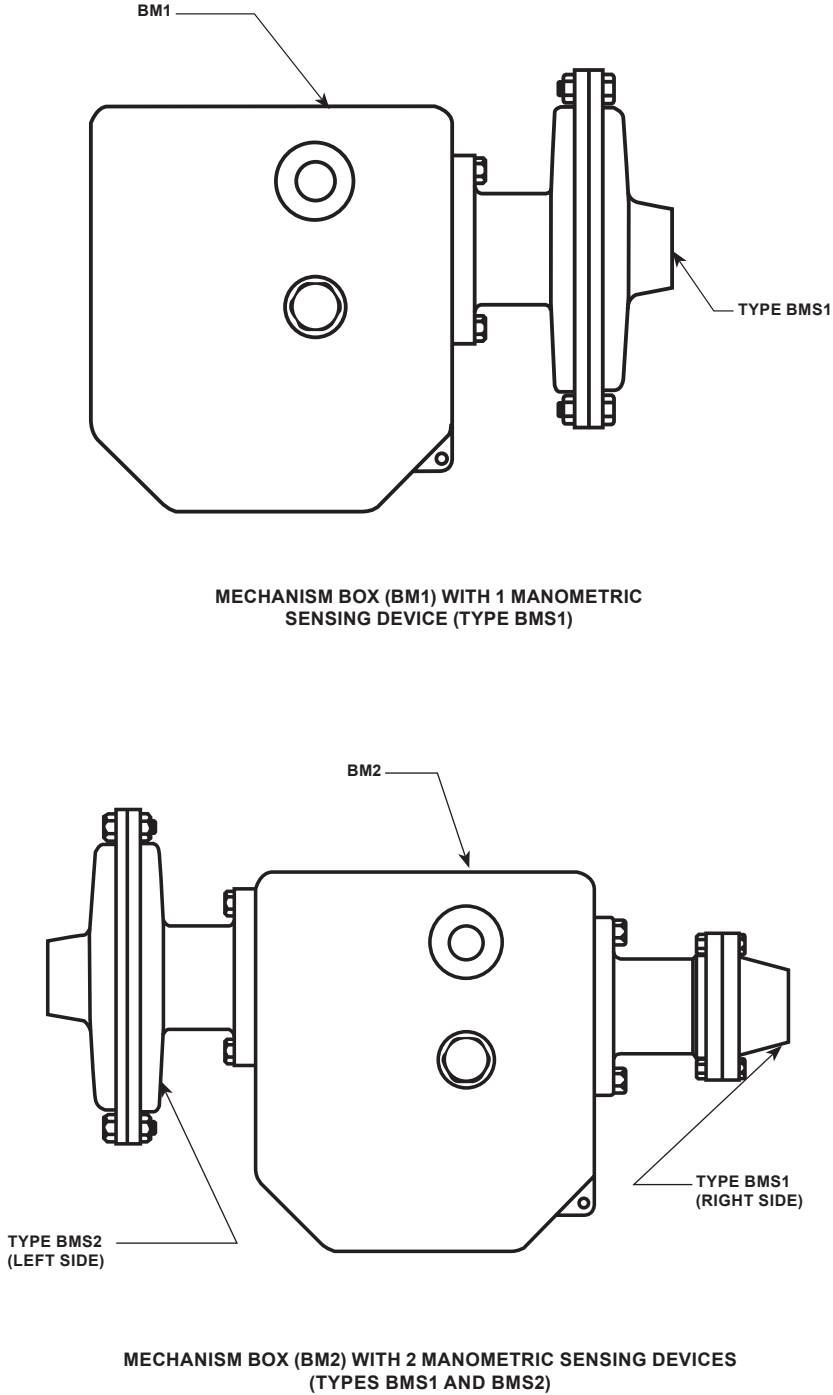

Figure 7. Types of Slam-Shut Installation

EZH and EZHSO Series

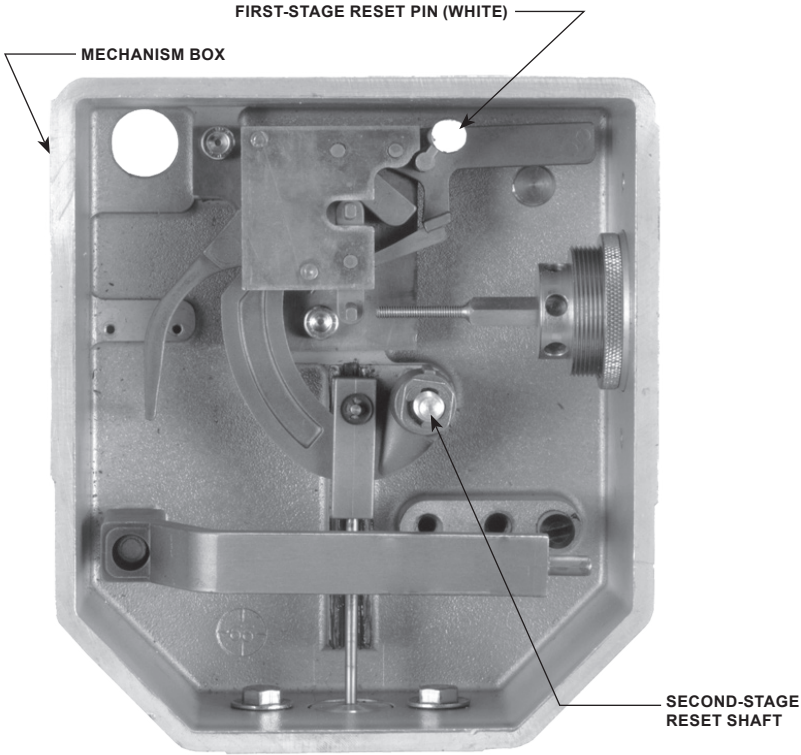

Figure 8. Slam-Shut Device in Open Position

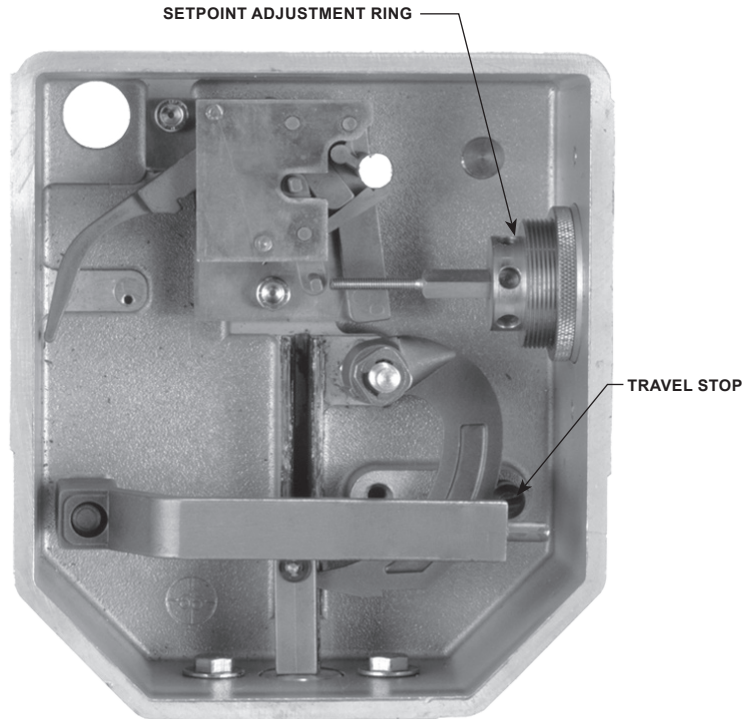

Figure 9. Slam-Shut Device in Closed Position

Slam-Shut Device Principle of Operation

The slam-shut device on the Type EZHOSX (Figure 6) can provide either overpressure (OPSO), overpressure and underpressure (OPSO/UPSO) or dual overpressure (OPSO/OPSO) protection by completely shutting off the flow of gas to the downstream system. Pressure is registered on one side of the diaphragm, piston or bellows and is opposed by the setpoint control spring of the manometric sensing device. The Type OSE slam-shut valve tripping pressure is determined by the setting of the control spring.

Overpressure: when the downstream pressure increases above the setpoint, the pressure on top of the diaphragm overcomes the spring setting and moves the manometric device stem.

Underpressure: when the downstream pressure decreases below the setpoint, the control spring pressure below the diaphragm overcomes the downstream pressure and pushes the diaphragm which moves the manometric device stem.

When the pressure of the downstream line rises above the set pressure (or drops below the set pressure) the manometric device senses the pressure change and triggers the detection stage which activates the second stage, releasing the slam-shut valve plug. Once the slam-shut device has been tripped, it must be manually reset.

See Figures 8 and 9 for the difference between the device in open and closed positions.

Capacity Information

Note

EZH and EZHSO Series flow capacities are laboratory verified; therefore, they may be sized for 100% flow using published capacities as shown. It is not necessary to reduce published capacities.

Tables 17 and 18 show the natural gas regulating capacities of the EZH and EZHSO Series regulators at selected inlet pressures and outlet pressure settings. Flows are in thousands of SCFH at 60°F and 14.7 psia (or in thousands of Nm³/h at 0°C and 1.01325 bar) of 0.6 specific gravity natural gas.

To determine equivalent capacities for air, propane, butane or nitrogen, multiply the capacity by the following appropriate conversion factor: 0.775 for air, 0.628 for propane, 0.548 for butane or 0.789 for nitrogen. For gases of other specific gravities, multiply the given capacity by 0.775 and divide by the square root of the appropriate specific gravity. Then, if capacity is desired in Nm³/h at 0°C and 1.01325 bar, multiply SCFH by 0.0268.

To find approximate regulating capacities at pressure settings not given in Tables 17 and 18 or to find wide-open flow capacities for relief sizing at any inlet pressure, perform one of the following procedures. Then convert using the factors provided above, if necessary.

Critical Pressure Drops

For critical pressure drops (absolute outlet pressure equal to or less than one-half of absolute inlet pressure), use the following formula:

$$Q = (P_1)(C_g)(1.29)$$

Non-Critical Pressure Drops

For pressure drops lower than critical (absolute outlet pressure greater than one-half of absolute inlet pressure).

$$Q = \sqrt{\frac{520}{GT}} C_g P_1 \text{SIN} \left(\frac{3417}{C_1} \sqrt{\frac{\Delta P}{P_1}} \right) \text{DEG}$$

where,

Q = gas flow rate, SCFH

P₁ = absolute inlet pressure, psia (P₁ gauge + 14.7)

C_g = regulating or wide-open gas sizing coefficient

G = gas specific gravity of the gas

T = absolute temperature of gas at inlet, °Rankine

C₁ = flow coefficient

ΔP = pressure drop across the regulator, psi

When sizing a working monitor setup, size each regulator separately using either the capacity tables or the equation method. When sizing a wide-open monitor setup, first use the equation method, solving for the pressure drop across the monitor at the maximum flow condition. Next size the worker using either the capacity tables or equation method while taking into account the monitor's maximum pressure drop.

EZH and EZHSO Series

Table 5. Manometric Device Specifications⁽¹⁾

SPRING RANGE		SPRING COLOR	SPRING PART NUMBER	MAXIMUM SENSING INLET PRESSURE		MANOMETRIC SENSING DEVICE TYPE	MANOMETRIC SENSING DEVICE STYLE	SETPOINT TOLERANCE ⁽¹⁾		MAXIMUM DIFFERENCE BETWEEN OVERPRESSURE AND UNDERPRESSURE ⁽²⁾	
psig	bar			psig	bar			psig	bar	psid	bar d
4.02 to 14.1 in. w.c.	10 to 35 mbar	Purple	T14232T0012	75	5.2	162	Diaphragm	0.058	0.004	0.145	0.01
9.97 to 33.2 in. w.c.	25 to 83 mbar	Orange	T14233T0012					0.073	0.005	0.363	0.03
18 in. w.c. to 2.0 psig	45 mbar to 0.14 bar	Red	T14234T0012					0.145	0.01	0.725	0.05
1.0 to 3.5	0.07 to 0.24	Yellow	T14235T0012					0.203	0.014	0.870	0.06
1.7 to 5.6	0.12 to 0.39	Green	T14236T0012					0.261	0.02	2.18	0.15
2 to 11	0.14 to 0.80	Gray	T14238T0012					0.725	0.05	5.08	0.35
4 to 19	0.28 to 1.3	Brown	T14239T0012					1.16	0.08	8.70	0.60
7 to 33	0.48 to 2.3	Black	T14240T0012	2.47	0.17	16.0	1.1				
15 to 75	1.0 to 5.2	Blue	T14237T0012	235	16.2	71	Diaphragm	5.08	0.35	36.3	2.5
31 to 161	2.1 to 11.1	Brown	T14239T0012					10.2	0.70	79.8	5.5
59 to 235	4.1 to 16.2	Black	T14240T0012					23.2	1.6	145	10.0
235 to 323	16.2 to 22.3	Brown	T14239T0012	1470	101	27	Piston	43.5	3.0	Requires use of Types BMS1 and BMS2	
323 to 588	22.3 to 40.5	Black	T14240T0012					94.3	6.5		
588 to 808	40.5 to 55.7	Brown	T14239T0012	1470	101	17	Piston	102	7.0		
808 to 1470	55.7 to 101	Black	T14240T0012					174	12.0		
81 to 323	5.58 to 22.3	Brown	T14239T0012	514	35.4	236	Bellows	14.5	1.00	145	10.0
122 to 514	8.4 to 35.4	Black	T14240T0012					36.3	2.5	290	20.0
257 to 1058	17.7 to 72.9	Gray	T14238T0012					1058	72.9	315	72.5

1. Minimum suggested difference between slam-shut set pressure and normal operating pressure of the system.
 2. Maximum difference between overpressure and underpressure when using one manometric device (Type BMS1) with tripping hook. For underpressure and overpressure points greater than this maximum number, use a second manometric device (Type BMS2) for underpressure protection.

Table 6. Applications and Construction Guide (See Figure 7)

APPLICATION	MECHANISM BOX REQUIRED		MANOMETRIC SENSING DEVICE REQUIRED	
	BM1	BM2	Type BMS1	Type BMS2
Overpressure Shutoff (OPSO)	Yes	No	Yes	No
Underpressure Shutoff (UPSO)			Yes ⁽¹⁾	
Overpressure Shutoff (OPSO) and Underpressure Shutoff (UPSO)			Yes ⁽²⁾	
Overpressure Shutoff (OPSO) and Underpressure Shutoff (UPSO)	No	Yes	Yes ⁽²⁾	Yes ⁽¹⁾

1. When using one manometric sensing device (Type BMS1) for both overpressure and underpressure shutoff, make sure that the difference between set pressures falls within the maximum range shown in Table 5.
 2. When using two manometric sensing devices (Types BMS1 and BMS2), the Type BMS1 can only be used for high trip.

EZH and EZHSO Series

Table 7. Types EZH and EZHSO Main Valve with Standard Cage Regulating Flow Coefficients

MAIN VALVE BODY SIZE		TRIM, % OF CAPACITY	LINE SIZE EQUALS BODY SIZE			2:1 LINE SIZE TO BODY SIZE PIPING		
NPS	DN		C _g	C _v	C _i	C _g	C _v	C _i
1	25	100	564	16.3	34.6	544	15.3	35.5
		80	436	12.3	35.4	423	10.9	38.7
		50	284	8.4	33.7	249	6.3	39.7
		30	172	5.3	32.5	157	4.0	39.1
2	50	100	2278	58.5	38.9	2110	62.9	33.5
		80	1719	47.1	36.5	1609	50.5	31.9
		50	1213	31.0	39.1	1177	33.0	35.6
		30	707	16.9	41.7	718	18.8	38.2
3	80	100	4960	133	37.3	4396	143	30.8
		80	3950	109	36.2	3294	97.2	33.9
		50	2550	63.6	40.1	2069	54.7	37.80
		30	1530	36.7	41.7	1339	39.8	33.6
4	100	100	7250	227	31.9	7170	229	31.3
		80	5750	165	34.8	5630	165	34.1
		50	3510	95.9	36.6	3460	95.5	36.2
		30	2130	56.7	37.6	2080	56.2	37.0
6	150	100	14,430	462	31.2	13,600	433	31.4
		80	11,270	344	32.8	11,260	313	35.9
		50	7150	206	34.7	7120	181	39.3
		30	4100	132	31.1	4070	132	30.8
8	200	100	26,540	720	36.9	25,270	722	35.0
		50	13,990	375	37.3	13,600	374	36.4
		30	7720	202	38.1	7860	205	38.3
12 X 6	300 X 150	100	30,490	815	37.4	29,270	783	37.4
		50	14,040	359	39.1	13,620	348	39.1
		30	8050	202	39.7	7890	198	39.7

Table 8. Types EZH and EZHSO with Standard Cage Wide-Open Flow Coefficients

MAIN VALVE BODY SIZE		TRIM, % OF CAPACITY	LINE SIZE EQUALS BODY SIZE			2:1 LINE SIZE TO BODY SIZE PIPING		
NPS	DN		C _g	C _v	C _i	C _g	C _v	C _i
1	25	100	587	16.95	34.63	566	15.94	35.51
		80	453	12.79	35.42	440	11.37	38.70
		50	295	8.76	33.68	259	6.52	39.72
		30	179	5.51	32.49	163	4.16	39.18
2	50	100	2369	60.89	38.91	2194	65.44	33.53
		80	1788	48.94	36.53	1673	52.52	31.85
		50	1261	32.26	39.09	1224	34.35	35.63
		30	735	17.62	41.71	747	19.57	38.17
3	80	100	5158	138	37.29	4571	149	30.77
		80	4108	113	36.24	3426	101	33.89
		50	2652	66.14	40.10	2152	56.94	37.79
		30	1591	38.17	41.68	1393	41.40	33.65
4	100	100	7470	234	31.6	7390	236	31.4
		80	5920	170	34.8	5800	170	34.2
		50	3620	98.8	36.7	3560	98.4	36.3
		30	2190	58.4	37.3	2140	57.9	37.3
6	150	100	14,870	476	31.2	14,010	446	31.4
		80	11,610	354	32.8	11,600	323	35.9
		50	7370	212	34.7	7340	187	39.3
		30	4230	136	31.1	4200	136	30.8
8	200	100	27,340	742	36.9	26,040	744	35.0
		50	14,410	386	37.3	14,000	385	36.3
		30	7950	209	38.1	8100	212	38.3
12 X 6	300 X 150	100	31,400	839	37.4	30,160	806	37.4
		50	14,460	370	39.1	14,030	359	39.1
		30	8290	208	39.7	8130	204	39.7

EZH and EZHSO Series

Table 9. Types EZH and EZHSO Main Valve with Standard Cage IEC Sizing Coefficients

MAIN VALVE BODY SIZE		TRIM, % OF CAPACITY	LINE SIZE EQUALS BODY SIZE			2:1 LINE SIZE TO BODY SIZE PIPING		
NPS	DN		X _T	F _D	F _L	X _T	F _D	F _L
1	25	100	0.61	0.61	0.89	0.80	0.59	0.89
		80	0.72	0.67		0.95	0.63	
		50	0.69	0.80		0.99	0.69	
		30	0.66	0.81		0.97	0.71	
2	50	100	0.73	0.59		0.69	0.61	
		80	0.84	0.68		0.72	0.70	
		50	0.97	0.69		0.84	0.72	
		30	0.99	0.70		0.92	0.74	
3	80	100	0.88	0.58		0.60	0.60	
		80	0.83	0.71		0.73	0.67	
		50	0.99	0.73		0.90	0.68	
		30	0.99	0.72		0.72	0.75	
4	100	100	0.63	0.63		0.62	0.63	
		80	0.76	0.74		0.74	0.74	
		50	0.85	0.77		0.83	0.77	
		30	0.88	0.78		0.88	0.77	
6	150	100	0.62	0.69	0.62	0.69		
		80	0.68	0.78	0.82	0.78		
		50	0.76	0.61	0.98	0.61		
		30	0.61	0.95	0.60	0.95		
8	200	100	0.86	0.69	0.77	0.69		
		50	0.88	0.78	0.83	0.78		
		30	0.92	0.61	0.93	0.61		
		12 X 6	300 X 150	100	0.88	0.69	0.88	0.69
		50	0.96	0.78	0.96	0.78		
		30	1.00	0.61	1.00	0.61		

Table 10. Type EZHOSX Main Valve with Standard Cage Regulating Flow Coefficients

MAIN VALVE BODY SIZE		TRIM, % OF CAPACITY	LINE SIZE EQUALS BODY SIZE			2:1 LINE SIZE TO BODY SIZE PIPING		
NPS	DN		C _g	C _v	C _i	C _g	C _v	C _i
1	25	100	560	16.3	34.4	550	17.6	31.3
		80	428	12.0	35.7	408	11.9	34.3
		50	282	8.3	33.9	245	7.3	33.6
		30	171	5.3	32.3	154	4.8	32.1
2	50	100	2259	53.5	42.3	2092	54.6	38.3
		80	1837	52.0	35.4	1762	50.0	35.3
		50	1297	32.9	39.4	1301	33.5	38.80
		30	746	17.9	41.7	746	18.3	40.80
3	80	100	4620	125	37.0	4359	142	30.8
		80	3920	106	37.0	3266	96.4	33.9
		50	2560	64.9	39.4	2052	54.3	37.80
		30	1540	36.8	41.8	1328	39.5	33.6
4	100	100	7120	209	34.1	6920	213	32.5
		80	5920	162	36.5	5760	163	35.3
		50	3550	93.3	38.0	3420	91.7	37.3
		30	2080	56.4	36.9	2060	55.6	37.1
6	150	100	13,930 ⁽¹⁾	412 ⁽¹⁾	33.8	13,280 ⁽¹⁾	405 ⁽¹⁾	32.8
		80	11,230 ⁽¹⁾	305 ⁽¹⁾	36.8	10,600 ⁽¹⁾	303 ⁽¹⁾	35.0
		50	7150 ⁽¹⁾	185 ⁽¹⁾	38.7	7150 ⁽¹⁾	185 ⁽¹⁾	38.8
		30	4020 ⁽¹⁾	101 ⁽¹⁾	39.8	4050 ⁽¹⁾	102 ⁽¹⁾	39.7
8	200	100	26,540	720	36.9	24,010	722	33.3
		50	13,910	375	37.1	12,670	374	33.9
		30	7720	202	38.1	7860	205	38.3

1. To avoid internal parts damage to the slamshut, the maximum recommended pressure drop (in psi) is equal to 1100 minus 0.075 multiplied by the max C_g for the application.
(Max ΔP= 1100-0.075*C_g)

EZH and EZHSO Series

Table 11. Type EZHOSX with Standard Cage Wide-Open Flow Coefficients

MAIN VALVE BODY SIZE		TRIM, % OF CAPACITY	LINE SIZE EQUALS BODY SIZE			2:1 LINE SIZE TO BODY SIZE PIPING		
NPS	DN		C _g	C _v	C ₁	C _g	C _v	C ₁
1	25	100	582	16.95	34.34	572	18.3	31.26
		80	445	12.48	35.66	424	12.38	34.25
		50	293	8.66	33.83	255	7.59	33.60
		30	178	5.51	32.30	160	4.99	32.06
2	50	100	2349	55.59	42.26	2176	56.75	38.34
		80	1911	54.04	35.36	1832	51.97	35.25
		50	1348	34.21	39.40	1352	34.87	38.77
		30	776	18.62	41.68	775	19.01	40.77
3	80	100	4805	130	36.96	4533	147	30.77
		80	4077	110	36.98	3397	100	33.89
		50	2662	67.50	39.44	2134	56.46	37.80
		30	1602	38.27	41.86	1381	41.05	33.64
4	100	100	7330	215	34.0	7130	219	32.4
		80	6100	167	36.5	5930	168	35.2
		50	3660	96.1	38.0	3520	94.5	37.4
		30	2140	58.1	36.9	2120	57.3	37.1
6	150	100	14,348	424	33.8	13,678	417	32.8
		80	11,567	314	36.8	10,918	312	35.0
		50	7365	191	38.7	7365	191	38.8
		30	4141	104	39.8	4172	105	39.7
8	200	100	29,510	778	37.9	26,040	749	34.8
		50	14,410	384	37.5	14,000	402	34.8
		30	7950	217	36.6	8100	208	38.9

Table 12. Type EZHOSX Main Valve with Standard Cage IEC Sizing Coefficients

MAIN VALVE BODY SIZE		TRIM, % OF CAPACITY	LINE SIZE EQUALS BODY SIZE			2:1 LINE SIZE TO BODY SIZE PIPING		
NPS	DN		X _T	F _D	F _L	X _T	F _D	F _L
1	25	100	0.75	0.61	0.89	0.94	0.61	0.89
		80	0.81	0.66		0.68	0.66	
		50	0.73	0.79		0.26	0.79	
		30	0.65	0.81		0.87	0.81	
2	50	100	0.78	0.56		0.86	0.56	
		80	0.79	0.71		0.92	0.71	
		50	0.98	0.71		0.95	0.71	
		30	0.99	0.72		0.99	0.72	
3	80	100	0.87	0.56		0.59	0.56	
		80	0.87	0.70		0.72	0.70	
		50	0.98	0.74		0.90	0.74	
		30	0.99	0.72		0.71	0.72	
4	100	100	0.73	0.61		0.66	0.61	
		80	0.84	0.73		0.78	0.73	
		50	0.91	0.76		0.88	0.76	
		30	0.86	0.77		0.87	0.77	
6	150	100	0.72	0.69	0.68	0.69		
		80	0.86	0.78	0.77	0.78		
		50	0.95	0.61	0.95	0.61		
		30	1.00	0.95	1.00	0.95		
8	200	100	0.87	0.69	0.87	0.69		
		50	0.87	0.78	0.87	0.78		
		30	0.92	0.61	0.92	0.61		

EZH and EZHSO Series

Table 13. Types EZH and EZHSO Main Valve with Whisper Trim™ Cage Regulating Flow Coefficients and Sizing Coefficients

MAIN VALVE BODY SIZE		TRIM, % OF CAPACITY	LINE SIZE EQUALS BODY SIZE			2:1 LINE SIZE TO BODY SIZE PIPING			IEC SIZING COEFFICIENTS				F _L
NPS	DN		C _g	C _v	C _i	C _g	C _v	C _i	1:1 Line to Body Size		2:1 Line to Body Size		
									X _T	F _D	X _T	F _D	
2	50	100	1627	42.5	38.3	1539	45.9	33.5	0.82	0.03	0.71	0.03	0.89
		80	1466	37.6	39.0	1389	40.7	34.1	0.90	0.03	0.74	0.03	
		50	1114	28.0	39.8	1099	30.8	35.7	0.99	0.02	0.81	0.02	
		30	689	16.6	41.6	695	18.4	37.7	0.99	0.02	0.90	0.02	
3	80	100	3502	103	34.1	3313	108	30.8	0.59	0.02	0.60	0.02	
		80	2928	81.4	36.0	2774	82.6	33.6	0.72	0.02	0.71	0.02	
		50	1934	49.3	39.2	1908	51.4	37.1	0.95	0.01	0.87	0.01	
		30	1355	32.9	41.2	1366	35.0	39.0	0.99	0.01	0.96	0.01	
4	100	100	5570	179	31.1	5410	178	30.4	0.61	0.02	0.59	0.02	
		80	4860	148	32.8	4730	146	32.4	0.67	0.02	0.66	0.02	
		50	3340	93.4	35.8	3320	93.0	35.7	0.80	0.01	0.79	0.01	
		30	2080	54.3	38.3	2050	55.0	37.3	0.92	0.01	0.88	0.01	
6	150	100	12,860	375	34.3	12,410	373	33.3	0.74	0.01	0.70	0.01	
		80	10,610	295	35.9	10,290	293	35.1	0.82	0.01	0.78	0.01	
		50	7140	191	37.4	7080	191	37.1	0.88	0.01	0.87	0.01	
		30	4040	102	39.8	4020	102	39.6	1.00	0.01	0.99	0.01	
8	200	100	20,620	518	39.8	19,570	598	32.8	1.00	0.01	0.68	0.01	
		50	13,180	333	39.6	12,850	327	39.3	0.99	0.01	0.98	0.01	
		30	7590	193	39.4	7550	191	39.6	0.98	0.01	0.99	0.01	
12 X 6	300 X 150	100	20,000	648	30.9	19,200	622	30.9	0.60	0.01	0.60	0.01	
		50	13,110	330	39.8	12,720	320	39.8	1.00	0.01	1.00	0.01	
		30	7570	190	39.8	7420	186	39.8	1.00	0.01	1.00	0.01	

Table 14. Types EZH and EZHSO Main Valve with Whisper Trim Cage Wide-Open Flow and Sizing Coefficients

MAIN VALVE BODY SIZE		TRIM, % OF CAPACITY	LINE SIZE EQUALS BODY SIZE			2:1 LINE SIZE TO BODY SIZE PIPING			IEC SIZING COEFFICIENTS				F _L
NPS	DN		C _g	C _v	C _i	C _g	C _v	C _i	1:1 Line to Body Size		2:1 Line to Body Size		
									X _T	F _D	X _T	F _D	
2	50	100	1692	44.2	38.2	1600	47.7	33.5	0.82	0.03	0.71	0.03	0.89
		80	1524	39.1	39.0	1444	42.3	34.1	0.90	0.03	0.74	0.03	
		50	1159	29.1	39.8	1143	31.9	35.8	0.99	0.02	0.81	0.02	
		30	718	17.2	41.7	722	19.2	37.6	0.99	0.02	0.90	0.02	
3	80	100	3642	107	34.1	3445	112	30.7	0.59	0.02	0.60	0.02	
		80	3045	84.7	35.9	2885	85.8	33.6	0.72	0.02	0.71	0.02	
		50	2011	51.3	39.2	1985	53.4	37.1	0.95	0.01	0.87	0.01	
		30	1409	34.2	41.2	1421	36.3	39.1	0.99	0.01	0.96	0.01	
4	100	100	5740	184	31.0	5570	183	30.5	0.61	0.02	0.59	0.02	
		80	5010	152	32.7	4870	150	32.4	0.67	0.02	0.66	0.02	
		50	3440	96.2	35.6	3420	95.8	35.3	0.80	0.01	0.79	0.01	
		30	2140	55.9	38.1	2110	56.7	37.3	0.92	0.01	0.88	0.01	
6	150	100	13,240	386	34.3	12,790	384	33.3	0.74	0.01	0.70	0.01	
		80	10,930	304	35.9	10,600	302	35.1	0.82	0.01	0.78	0.01	
		50	7350	197	37.4	7290	197	37.0	0.88	0.01	0.87	0.01	
		30	4160	105	39.7	4140	105	39.5	1.00	0.01	0.99	0.01	
8	200	100	21,230	534	39.8	20,160	615	32.8	1.00	0.01	0.68	0.01	
		50	13,580	343	39.6	13,240	337	39.3	0.99	0.01	0.98	0.01	
		30	7820	198	39.4	7770	196	39.6	0.98	0.01	0.99	0.01	
12 X 6	300 X 150	100	20,600	668	30.9	19,780	641	30.9	0.60	0.01	0.60	0.01	
		50	13,500	340	39.8	13,100	329	39.8	1.00	0.01	1.00	0.01	
		30	7800	196	39.8	7640	192	39.8	1.00	0.01	1.00	0.01	

EZH and EZHSO Series

Table 15. Type EZHOSX Main Valve with Whisper Trim™ Cage Regulating Flow and Sizing Coefficients

MAIN VALVE BODY SIZE		TRIM, % OF CAPACITY	LINE SIZE EQUALS BODY SIZE			2:1 LINE SIZE TO BODY SIZE PIPING			IEC SIZING COEFFICIENTS				F _L
NPS	DN		C _g	C _v	C _i	C _g	C _v	C _i	1:1 Line to Body Size		2:1 Line to Body Size		
									X _T	F _D	X _T	F _D	
2	50	100	1494	39.9	37.4	1516	41.0	37.0	0.89	0.03	0.87	0.03	0.89
		80	1473	39.3	37.5	1482	39.5	37.5	0.89	0.03	0.89	0.03	
		50	1171	30.0	39.0	1169	29.6	39.5	0.96	0.02	0.99	0.02	
		30	721	17.0	42.4	718	18.2	39.4	0.99	0.02	0.98	0.02	
3	80	100	3472	102	34.1	3285	107	30.8	0.73	0.02	0.59	0.02	
		80	2903	80.7	36.0	2751	81.9	33.6	0.82	0.02	0.71	0.02	
		50	1918	48.9	39.2	1892	51.0	37.1	0.97	0.01	0.86	0.01	
		30	1344	32.6	41.2	1354	34.7	39.0	0.99	0.01	0.96	0.01	
4	100	100	5490	167	32.9	5320	168	31.7	0.68	0.02	0.63	0.02	
		80	4960	144	34.4	4810	141	34.1	0.74	0.02	0.73	0.02	
		50	3270	89.9	36.4	3190	87.7	36.4	0.83	0.01	0.86	0.01	
		30	2040	54.4	37.5	2020	53.7	37.6	0.89	0.01	0.90	0.01	
6	150	100	12,240 ⁽¹⁾	353 ⁽¹⁾	34.7	11,840 ⁽¹⁾	348 ⁽¹⁾	34.0	0.76	0.01	0.73	0.01	
		80	9970 ⁽¹⁾	275 ⁽¹⁾	36.3	9650 ⁽¹⁾	275 ⁽¹⁾	35.0	0.83	0.01	0.78	0.01	
		50	6970 ⁽¹⁾	181 ⁽¹⁾	38.6	6780 ⁽¹⁾	180 ⁽¹⁾	37.6	0.94	0.01	0.89	0.01	
		30	3990 ⁽¹⁾	100 ⁽¹⁾	39.8	3950 ⁽¹⁾	99.9 ⁽¹⁾	39.6	1.00	0.01	0.99	0.01	
8	200	100	20,620	518	39.8	19,380	598	32.4	1.00	0.01	0.68	0.01	
		50	13,180	333	39.6	12,460	327	38.1	0.99	0.01	0.98	0.01	
		30	7590	193	39.4	7550	191	39.6	0.98	0.01	0.99	0.01	

1. To avoid internal parts damage to the slamshut, the maximum recommended pressure drop (in psi) is equal to 1100 minus 0.075 multiplied by the max C_g for the application. (Max ΔP= 1100-0.075*C_g)

Table 16. Type EZHOSX Main Valve with Whisper Trim Cage Wide-Open Flow and Sizing Coefficients

MAIN VALVE BODY SIZE		TRIM, % OF CAPACITY	LINE SIZE EQUALS BODY SIZE			2:1 LINE SIZE TO BODY SIZE PIPING			IEC SIZING COEFFICIENTS				F _L
NPS	DN		C _g	C _v	C _i	C _g	C _v	C _i	1:1 Line to Body Size		2:1 Line to Body Size		
									X _T	F _D	X _T	F _D	
2	50	100	1554	41.5	37.4	1577	42.6	37.1	0.89	0.03	0.87	0.03	0.89
		80	1532	40.9	37.5	1542	41.1	37.5	0.89	0.03	0.89	0.03	
		50	1218	31.2	39.0	1216	30.8	39.4	0.96	0.02	0.99	0.02	
		30	750	17.7	42.3	747	19.0	39.3	0.99	0.02	0.98	0.02	
3	80	100	3611	106	34.1	3416	111	30.7	0.73	0.03	0.59	0.03	
		80	3020	84.0	35.9	2861	85.2	33.6	0.82	0.03	0.71	0.03	
		50	1994	50.9	39.1	1968	53.0	37.1	0.97	0.02	0.86	0.02	
		30	1397	33.9	41.2	1409	36.1	39.0	0.99	0.02	0.96	0.02	
4	100	100	5650	172	32.9	5480	173	31.6	0.68	0.02	0.63	0.02	
		80	5110	148	34.2	4950	145	34.1	0.74	0.02	0.73	0.02	
		50	3370	92.6	36.3	3290	89.7	36.8	0.83	0.01	0.86	0.01	
		30	2100	56.0	37.6	2080	55.3	37.6	0.89	0.01	0.90	0.01	
6	150	100	12,610	363	34.7	12,200	359	34.0	0.76	0.01	0.73	0.01	
		80	10,270	283	36.3	9940	284	35.0	0.83	0.01	0.78	0.01	
		50	7190	186	38.6	6990	186	37.6	0.94	0.01	0.89	0.01	
		30	4120	104	39.8	4080	103	39.8	1.00	0.01	0.99	0.01	
8	200	100	22,250	559	39.8	19,960	627	31.8	1.00	0.01	0.64	0.01	
		50	13,580	358	37.9	12,840	332	38.7	0.91	0.01	0.95	0.01	
		30	7820	209	37.4	7770	204	38.1	0.89	0.01	0.92	0.01	

EZH and EZHSO Series

Table 17. Capacities for Types EZH and EZHSO with PRX Series Pilot and Type SA/2 Pilot Supply Filter Regulator

INLET PRESSURE		OUTLET PRESSURE		CAPACITIES IN THOUSANDS OF SCFH / Nm ³ /h OF 0.6 SPECIFIC GRAVITY NATURAL GAS USING 1:1 LINE SIZE TO BODY SIZE PIPING													
				NPS 1 / DN 25		NPS 2 / DN 50		NPS 3 / DN 80		NPS 4 / DN 100		NPS 6 / DN 150		NPS 8 / DN 200		NPS 12 X 6 / DN 300 X 150	
psig	bar	psig	bar	SCFH	Nm ³ /h	SCFH	Nm ³ /h	SCFH	Nm ³ /h	SCFH	Nm ³ /h	SCFH	Nm ³ /h	SCFH	Nm ³ /h	SCFH	Nm ³ /h
30	2.1	15	1.0	27	0.7	112	3.0	229	6.1	365	9.8	745	19.9	1233	33.0	1403	37.6
40	2.8	15	1.0	37	0.9	149	4.0	309	8.2	483	13.0	980	26.2	1663	44.6	1896	50.8
		25	1.7	31	0.8	128	3.4	260	6.9	420	11.3	858	23.0	1403	37.6	1596	42.7
50	3.4	15	1.0	45	1.2	183	4.9	382	10.2	588	15.8	1189	31.8	2056	55.1	2347	62.9
		25	1.7	41	1.1	169	4.5	347	9.3	550	14.8	1118	29.9	1870	50.1	2130	57.1
		35	2.4	35	0.9	142	3.8	288	7.7	469	12.6	959	25.7	1556	41.7	1768	47.4
60	4.1	16	1.1	53	1.4	214	5.7	450	12.0	687	18.4	1384	37.1	2420	64.8	2765	74.1
		20	1.3	52	1.3	211	5.6	440	11.8	678	18.2	1371	36.7	2368	63.5	2703	72.4
		30	2.0	48	1.3	197	5.3	406	10.8	641	17.2	1302	34.9	2186	58.6	2490	66.7
		45	3.1	38	1.0	156	4.2	314	8.4	513	13.8	1051	28.2	1695	45.4	1926	51.6
75	5.2	22	1.5	63	1.7	257	6.9	541	14.5	825	22.1	1662	44.5	2908	77.9	3322	89.0
		30	2.0	61	1.6	250	6.7	520	13.9	806	21.6	1632	43.7	2798	75.0	3192	85.5
		40	2.7	58	1.5	235	6.3	483	12.9	764	20.5	1553	41.6	2601	69.7	2963	79.4
		60	4.1	42	1.1	174	4.6	349	9.3	574	15.4	1177	31.5	1886	50.5	2142	57.4
100	6.9	32	2.2	81	2.2	329	8.8	692	18.5	1055	28.3	2126	57.0	3722	99.7	4251	114
		40	2.7	79	2.1	322	8.6	672	18.0	1038	27.9	2099	56.2	3616	96.9	4126	111
		50	3.4	76	2.0	309	8.3	639	17.1	1003	26.9	2035	54.5	3441	92.2	3921	105
		85	5.8	49	1.3	200	5.3	401	10.7	663	17.8	1362	36.5	2167	58.1	2460	65.9
125	8.6	43	2.9	99	2.7	400	10.7	841	22.6	1283	34.4	2588	69.3	4523	121	5166	138
		50	3.4	97	2.6	394	10.6	824	22.1	1269	34.1	2565	68.7	4432	119	5058	136
		75	5.2	88	2.4	356	9.5	730	19.6	1163	31.2	2368	63.4	3939	106	4484	120
		110	7.5	55	1.4	224	6.0	447	12.0	742	19.9	1525	40.9	2417	64.8	2743	73.5
150	10.3	52	3.5	117	3.1	473	12.7	994	26.6	1515	40.7	3054	81.8	5348	143	6109	164
		75	5.2	110	2.9	449	12.0	929	24.9	1453	39.0	2947	79.0	5004	134	5704	153
		95	6.5	101	2.7	411	11.0	841	22.5	1345	36.1	2740	73.4	4535	122	5162	138
		130	8.9	68	1.8	278	7.5	557	14.9	923	24.8	1895	50.8	3011	80.7	3418	91.6
200	13.8	73	5.0	152	4.1	616	16.5	1295	34.7	1974	53.0	3979	107	6963	187	7953	213
		100	6.9	145	3.9	588	15.8	1219	32.7	1903	51.1	3858	103	6564	176	7484	200
		125	8.6	133	3.6	544	14.6	1113	29.8	1775	47.7	3616	96.9	6004	161	6835	183
		185	12.8	69	1.8	283	7.6	563	15.1	940	25.2	1935	51.8	3046	81.6	3456	92.6
300	20.7	115	7.9	222	6.0	902	24.2	1895	50.8	2892	77.6	5830	156	10,193	273	11,641	312
		150	10.3	213	5.7	866	23.2	1798	48.2	2802	75.2	5678	152	9683	259	11,042	296
		200	13.8	190	5.1	773	20.7	1579	42.3	2532	67.9	5162	138	8517	228	9691	260
		275	19.0	107	2.9	440	11.8	877	23.5	1462	39.2	3007	80.5	4741	127	5379	144
400	27.6	155	10.7	293	7.9	1189	31.9	2500	67.0	3813	102	7685	206	13,446	360	15,357	411
		200	13.8	282	7.6	1145	30.7	2377	63.7	3701	99.3	7497	201	12,801	343	14,598	391
		250	17.2	261	7.0	1061	28.4	2176	58.3	3463	92.9	7048	189	11,733	314	13,358	358
		300	20.7	227	6.1	926	24.8	1876	50.3	3047	81.8	6230	167	10,126	271	11,511	308
500	34.5	350	24.1	171	4.6	698	18.7	1399	37.5	2316	62.2	4757	127	7559	202	8580	230
		196	13.5	364	9.8	1476	39.6	3103	83.2	4732	127	9538	256	16,687	447	19,060	511
		250	17.2	350	9.4	1423	38.1	2956	79.2	4600	123	9315	250	15,918	426	18,154	486
		300	20.7	330	8.8	1345	36	2765	74.1	4379	117	8905	239	14,905	399	16,977	455
600	41.4	400	27.6	259	7	1058	28.4	2134	57.2	3492	93.6	7153	192	11,522	309	13,091	351
		250	17.2	432	11.6	1752	47	3675	98.5	5628	151	11,356	304	19,771	530	22,575	605
		300	20.7	419	11.2	1701	45.6	3535	94.7	5498	147	11,134	298	19,035	510	21,709	582
		350	24.1	400	10.7	1626	43.6	3351	89.8	5289	142	10,748	288	18,058	484	20,572	551
700	48.3	450	31	338	9.1	1378	37	2793	74.9	4535	122	9273	248	15,079	404	17,142	459
		500	34.5	288	7.7	1176	31.5	2364	63.4	3889	104	7976	214	12,772	342	14,505	389
		250	17.2	510	13.7	2068	55.4	4366	117	6607	177	13,294	356	23,472	629	26,824	719
		300	20.7	501	13.4	2032	54.5	4256	114	6530	175	13,181	353	22,898	613	26,142	700
700	48.3	350	24.1	487	13.1	1979	53	4114	110	6397	171	12,952	347	22,152	593	25,264	677
		400	27.6	469	12.6	1907	51.1	3934	105	6196	166	12,583	337	21,200	568	24,155	647
		550	37.9	371	10	1514	40.6	3058	82	4992	134	10,221	274	16,513	442	18,764	503
		600	41.4	314	8.4	1283	34.4	2575	69	4251	114	8725	234	13,913	373	15,796	423

- continued -

EZH and EZHSO Series

Table 17. Capacities for Types EZH and EZHSO with PRX Series Pilot and Type SA/2 Pilot Supply Filter Regulator (continued)

INLET PRESSURE		OUTLET PRESSURE		CAPACITIES IN THOUSANDS OF SCFH / Nm ³ /h OF 0.6 SPECIFIC GRAVITY NATURAL GAS USING 1:1 LINE SIZE TO BODY SIZE PIPING													
				NPS 1 / DN 25		NPS 2 / DN 50		NPS 3 / DN 80		NPS 4 / DN 100		NPS 6 / DN 150		NPS 8 / DN 200		NPS 12 X 6 / DN 300 X 150	
psig	bar	psig	bar	SCFH	Nm ³ /h	SCFH	Nm ³ /h	SCFH	Nm ³ /h	SCFH	Nm ³ /h	SCFH	Nm ³ /h	SCFH	Nm ³ /h	SCFH	Nm ³ /h
800	55.2	300	20.7	579	15.5	2349	63	4951	133	7517	202	15,135	405	26,623	713	30,418	815
		350	24.1	569	15.2	2311	62	4836	130	7431	199	15,005	402	26,023	697	29,706	796
		400	27.6	556	14.9	2257	60.5	4693	126	7295	196	14,770	396	25,268	677	28,820	772
		450	31	538	14.4	2187	58.6	4517	121	7100	190	14,413	386	24,334	652	27,731	743
		500	34.5	515	13.8	2096	56.2	4301	115	6835	184	13,910	373	23,186	621	26,401	707
		609	42	441	11.8	1800	48.2	3644	97.7	5926	159	12,121	325	19,674	527	22,363	599
650	44.8	401	10.7	1639	44	3302	88.5	5414	145	11,094	297	17,836	478	20,261	543		
900	62.1	350	24.1	649	17.4	2630	70.5	5535	148	8424	226	16,972	455	29,767	797	34,004	911
		400	27.6	638	17.1	2589	69.4	5416	145	8331	224	16,827	451	29,145	781	33,268	891
		500	34.5	606	16.2	2466	66.1	5098	137	8003	214	16,241	435	27,465	736	31,302	839
		600	41.4	557	15	2271	60.9	4641	124	7428	199	15,141	406	25,031	671	28,487	763
		800	55.2	361	9.7	1475	39.5	2952	79.1	4897	131	10,062	270	15,955	427	18,108	485
1000	69	350	24.1	726	19.5	2942	79	6219	167	9391	252	18,886	506	33,433	896	38,214	1024
		400	27.6	718	19.2	2910	78	6118	164	9330	250	18,805	504	32,906	882	37,584	1007
		500	34.5	693	18.6	2814	75.4	5851	157	9092	244	18,406	493	31,502	844	35,930	963
		600	41.4	654	17.5	2662	71.3	5477	147	8665	232	17,615	472	29,519	791	33,624	901
		800	55.2	514	13.8	2097	56.2	4231	113	6922	186	14,179	380	22,851	612	25,962	696
1100	75.8	350	24.1	802	21.5	3248	87	6894	185	10,342	277	20,766	556	37,045	992	42,363	1135
		450	31	786	21.1	3190	85.5	6700	180	10,234	275	20,636	553	36,041	966	41,160	1103
		500	34.5	775	20.8	3147	84.3	6576	176	10,131	272	20,470	548	35,388	948	40,388	1082
		600	41.4	744	20	3025	81.1	6259	168	9807	263	19,891	533	33,718	903	38,435	1030
		800	55.2	635	17	2589	69.4	5261	141	8504	228	17,374	465	28,390	761	32,284	865
		1000	68.9	402	10.8	1646	44.1	3287	88.1	5469	147	11,245	301	17,766	476	20,159	540
1200	82.7	350	24.1	877	24	3551	95.2	7562	203	11,281	302	22,620	606	40,621	1088	46,471	1245
		500	34.5	855	23	3470	93	7282	195	11,137	298	22,465	602	39,174	1049	44,733	1198
		600	41.4	829	22.2	3370	90.3	7008	188	10,888	292	22,043	591	37,735	1011	43,040	1153
		800	55.2	741	19.9	3020	80.9	6172	165	9876	265	20,129	539	33,288	892	37,883	1015
		1100	75.8	422	11.3	1724	46.2	3442	92.2	5734	154	11,792	316	18,607	498	21,111	566
1300	89.6	350	24.1	952	26	3852	103	8224	220	12,211	327	24,457	655	44,169	1183	50,547	1354
		500	34.5	934	25	3786	101	7976	214	12,121	325	24,412	654	42,889	1149	48,999	1313
		600	41.4	912	24.4	3704	99.3	7735	207	11,930	320	24,110	646	41,627	1115	47,505	1273
		800	55.2	839	22.5	3414	91.5	7014	188	11,125	298	22,628	606	37,812	1013	43,061	1154
		1160	80	513	13.7	2096	56.2	4193	112	6958	187	14,299	383	22,661	607	25,718	689
1400	96.5	350	24.1	1026	27.5	4151	111	8883	238	13,140	352	26,280	704	47,696	1278	54,601	1463
		500	34.5	1011	27.1	4098	110	8660	232	13,088	351	26,325	705	46,552	1247	53,206	1425
		600	41.4	993	26.6	4029	108	8444	226	12,942	347	26,118	700	45,432	1217	51,872	1390
		800	55.2	930	25	3785	101	7812	209	12,294	330	24,961	669	42,094	1128	47,966	1285
		1160	80	674	18.1	2753	73.8	5540	148	9102	244	18,663	500	29,923	802	33,986	910
1480	102	350	24.1	1085	29.1	4388	118	9408	252	13,883	372	27,731	743	50,507	1353	57,831	1549
		500	34.5	1072	28.7	4344	116	9201	247	13,852	371	27,837	746	49,455	1325	56,539	1515
		600	41.4	1056	28.3	4284	115	9004	241	13,737	369	27,692	742	48,428	1297	55,311	1482
		800	55.2	1001	26.8	4070	109	8428	226	13,188	354	26,744	716	45,396	1216	51,751	1386
		1160	80	782	21	3191	85.5	6447	173	10,518	282	21,532	577	34,812	933	39,561	1060

EZH and EZHSO Series

Table 18. Capacities for Type EZHOSX with PRX Series Pilot and Type SA/2 Pilot Supply Filter Regulator

INLET PRESSURE		OUTLET PRESSURE		CAPACITIES IN THOUSANDS OF SCFH / Nm ³ /h OF 0.6 SPECIFIC GRAVITY NATURAL GAS USING 1:1 LINE SIZE TO BODY SIZE PIPING											
				NPS 1 / DN 25		NPS 2 / DN 50		NPS 3 / DN 80		NPS 4 / DN 100		NPS 6 / DN 150		NPS 8 / DN 200	
psig	bar	psig	bar	SCFH	Nm ³ /h	SCFH	Nm ³ /h	SCFH	Nm ³ /h	SCFH	Nm ³ /h	SCFH	Nm ³ /h	SCFH	Nm ³ /h
30	2.1	15	1.0	27	0.7	108	2.9	214	5.7	351	9.4	686	18.4	1233	33.0
40	2.8	15	1.0	36	0.9	145	3.9	289	7.7	467	12.5	914	24.5	1663	44.6
		25	1.7	31	0.8	124	3.3	244	6.5	401	10.8	785	21.0	1403	37.6
50	3.5	15	1.0	45	1.2	179	4.8	357	9.5	572	15.4	1120	30.0	2056	55.1
		25	1.7	41	1.1	164	4.4	325	8.7	529	14.2	1035	27.7	1870	50.1
		35	2.4	35	0.9	138	3.6	270	7.2	447	12.0	873	23.4	1556	41.7
60	4.1	16	1.1	52	1.4	210	5.6	421	11.2	669	18.0	1312	35.1	2420	64.8
		20	1.3	52	1.4	206	5.5	412	11.0	659	17.7	1291	34.6	2368	63.5
		30	2.0	48	1.2	192	5.1	380	10.1	617	16.6	1208	32.4	2186	58.6
		45	3.1	38	1.0	150	4.0	294	7.9	489	13.1	955	25.6	1695	45.4
75	5.8	22	1.5	63	1.7	252	6.7	505	13.5	804	21.6	1576	42.2	2908	77.9
		30	2.0	61	1.6	244	6.5	486	13.0	781	21.0	1530	41.0	2798	75.0
		40	2.7	57	1.5	228	6.1	452	12.1	735	19.7	1439	38.5	2601	69.7
		60	4.1	42	1.1	167	4.4	327	8.7	545	14.6	1065	28.5	1886	50.5
100	6.9	32	2.2	81	2.2	323	8.6	647	17.3	1029	27.6	2016	54.0	3722	99.7
		40	2.7	79	2.1	315	8.4	628	16.8	1008	27.0	1973	52.9	3616	96.9
		50	3.4	75	2.0	301	8.0	598	16.0	968	26.0	1895	50.8	3441	92.2
		85	5.8	49	1.3	193	5.1	376	10.1	629	16.9	1228	32.9	2167	58.1
125	8.6	43	2.9	98	2.6	392	10.5	786	21.1	1251	33.5	2452	65.7	4523	121.2
		50	3.4	96	2.5	386	10.3	770	20.6	1233	33.0	2415	64.7	4432	118.7
		75	5.1	87	2.3	346	9.2	684	18.3	1117	30.0	2186	58.5	3939	105.5
		110	7.5	54	1.4	215	5.7	420	11.2	703	18.8	1372	36.8	2417	64.8
150	10.3	52	3.5	116	3.1	464	12.4	929	24.9	1478	39.6	2897	77.6	5348	143.3
		75	5.1	110	2.9	437	11.7	869	23.3	1405	37.7	2750	73.7	5004	134.0
		95	6.5	100	2.7	399	10.7	788	21.1	1290	34.6	2522	67.6	4535	121.5
		130	8.9	68	1.8	268	7.2	523	14.0	875	23.5	1708	45.8	3011	80.7
200	13.8	73	5.0	151	4.0	604	16.2	1210	32.4	1925	51.6	3773	101	6963	187
		100	6.9	144	3.9	573	15.4	1140	30.6	1841	49.3	3604	96.5	6564	175.9
		125	8.6	133	3.6	528	14.2	1043	28.0	1705	45.7	3334	89.3	6004	160.8
		185	12.8	69	1.8	272	7.3	529	14.1	889	23.8	1735	46.5	3046	81.6
300	20.7	115	7.9	221	5.9	884	23.7	1771	47.5	2819	75.7	5525	148	10,193	273
		150	10.3	212	5.7	845	22.6	1682	45.1	2712	72.8	5310	142	9683	259
		200	13.8	188	5.0	750	20.1	1479	39.6	2426	65.1	4744	127	8517	228
		275	19.0	107	2.9	422	11.3	823	22.1	1383	37.1	2699	72.3	4741	127.0
400	27.6	155	10.7	291	7.8	1166	31.2	2337	62.6	3718	99.8	7286	195	13,446	360
		200	13.8	280	7.5	1117	30.0	2224	59.6	3583	96.2	7016	188	12,801	343
		250	17.2	259	6.9	1031	27.6	2038	54.6	3327	89.3	6508	174	11,733	314
		300	20.7	225	6.0	895	24.0	1758	47.1	2907	78.0	5681	152	10,126	271
500	34.5	350	24.1	170	4.6	672	18.0	1312	35.2	2196	58.9	4287	115	7559	202
		196	13.5	361	9.7	1447	38.8	2900	77.7	4614	124	9042	242	16,687	447
		250	17.2	348	9.3	1389	37.2	2766	74.1	4454	119	8721	234	15,918	426
		300	20.7	328	8.8	1308	35.1	2589	69.4	4215	113	8246	221	14,905	399
500	34.5	400	27.6	257	6.9	1021	27.4	2001	53.6	3323	89.2	6492	174	11,522	309

- continued -

EZH and EZHSO Series

Table 18. Capacities for Type EZHOSX with PRX Series Pilot and Type SA/2 Pilot Supply Filter Regulator (continued)

INLET PRESSURE		OUTLET PRESSURE		CAPACITIES IN THOUSANDS OF SCFH / Nm ³ /h OF 0.6 SPECIFIC GRAVITY NATURAL GAS USING 1:1 LINE SIZE TO BODY SIZE PIPING											
				NPS 1 / DN 25		NPS 2 / DN 50		NPS 3 / DN 80		NPS 4 / DN 100		NPS 6 / DN 150		NPS 8 / DN 200	
psig	bar	psig	bar	SCFH	Nm ³ /h	SCFH	Nm ³ /h	SCFH	Nm ³ /h	SCFH	Nm ³ /h	SCFH	Nm ³ /h	SCFH	Nm ³ /h
600	41.4	250	17.2	429	11.5	1717	46	3436	92.1	5480	147	10,737	288	19,771	530
		300	20.7	416	11.1	1661	44.5	3307	88.6	5325	143	10,426	279	19,035	510
		350	24.1	397	10.6	1583	42.4	3137	84.1	5097	137	9973	267	18,058	484
		450	31	335	9	1333	35.7	2618	70.2	4328	116	8458	227	15,079	404
		500	34.5	286	7.7	1133	30.4	2217	59.4	3695	99	7217	193	12,772	342
700	48.3	250	17.2	507	13.6	2031	54.4	4079	109	6460	173	12,664	339	23,472	629
		300	20.7	497	13.3	1990	53.4	3979	107	6354	170	12,449	333	22,898	613
		350	24.1	484	13	1933	51.8	3849	103	6196	166	12,131	325	22,152	593
		400	27.6	465	12.5	1857	49.8	3683	98.7	5975	160	11,692	313	21,200	568
		550	37.4	368	9.9	1462	39.2	2867	77	4755	127	9291	249	16,513	442
600	41.4	312	8.4	1236	33.1	2415	64.7	4034	108	7877	211	13,913	373		
800	55.2	300	20.7	575	15.4	2306	61.8	4627	124	7341	197	14,390	385	26,623	713
		350	24.1	565	15.1	2262	60.6	4522	121	7227	194	14,158	379	26,023	697
		400	27.6	552	14.8	2204	59.1	4390	118	7066	189	13,836	371	25,268	677
		450	31	534	14.3	2130	57.1	4227	113	6851	184	13,408	359	24,334	652
		500	34.5	511	13.7	2036	54.6	4027	108	6571	176	12,853	344	23,186	621
609	42	438	11.7	1740	46.6	3416	91.5	5652	151	11,045	296	19,674	527		
650	44.8	399	10.7	1581	42.4	3097	83	5149	138	10,059	269	17,836	478		
900	62.1	350	24.1	644	17.3	2580	69.1	5173	139	8220	220	16,111	432	29,767	797
		400	27.6	633	17	2534	68	5064	136	8099	217	15,867	425	29,145	781
		500	34.5	602	16.1	2403	64.4	4771	128	7726	207	15,121	405	27,465	736
		600	41.4	553	14.8	2203	59	4347	117	7123	191	13,930	373	25,031	671
		800	55.2	358	9.6	1420	38.1	2770	74.2	4639	124	9057	243	15,955	427
1000	69	350	24.1	721	19.3	2891	77.5	5811	156	9189	246	18,017	483	33,433	896
		400	27.6	712	19.1	2854	76.5	5719	153	9097	244	17,829	478	32,906	882
		500	34.5	688	18.4	2748	73.6	5473	146	8808	236	17,246	462	31,502	844
		600	41.4	649	17.4	2589	69.4	5128	137	8343	224	16,322	437	29,519	791
		800	55.2	510	13.7	2025	54.3	3968	106	6589	177	12,872	345	22,851	612
1100	75.8	350	24.1	796	21.3	3197	85.7	6439	173	10,142	272	19,892	533	37,045	992
		450	31	781	20.9	3127	83.8	6263	168	9974	267	19,545	524	36,041	966
		500	34.5	770	20.6	3079	82.5	6149	165	9844	264	19,282	517	35,388	948
		600	41.4	739	19.8	2948	79	5858	157	9474	254	18,543	497	33,718	903
		800	55.2	630	16.9	2506	67.2	4930	132	8128	218	15,887	426	28,390	761
1000	69	400	10.7	1582	42.4	3084	82.7	5176	139	10,103	271	17,766	476		
1200	82.7	350	24.1	871	23.3	3500	93.8	7061	189	11,084	297	21,745	583	40,621	1088
		500	34.5	849	22.8	3401	91.1	6807	182	10,894	292	21,259	570	39,174	1049
		600	41.4	824	22.1	3291	88.2	6556	176	10,549	283	20,656	553	37,735	1011
		800	55.2	736	19.7	2929	78.5	5781	155	9472	254	18,522	496	33,288	892
		1100	75.8	419	11.2	1658	44.4	3230	86.6	5424	145	10,588	284	18,607	498
1300	89.6	350	24.1	945	25.3	3800	102	7678	206	12,018	322	23,582	632	44,169	1183
		500	34.5	927	24.8	3716	99.6	7454	200	11,833	317	23,194	621	42,889	1149
		600	41.4	906	24.3	3623	97.1	7233	194	11,587	311	22,696	608	41,627	1115
		800	55.2	833	22.3	3319	88.9	6568	176	10,702	287	20,936	561	37,812	1013
		1160	80	509	13.6	2017	54.1	3934	105	6591	177	12,868	345	22,661	607
1400	96.5	350	24.1	1019	27.3	4099	110	8292	222	12,946	347	25,408	681	47,696	1278
		500	34.5	1004	26.9	4027	108	8091	217	12,802	343	25,099	672	46,552	1247
		600	41.4	986	26.4	3946	106	7895	212	12,598	338	24,684	661	45,432	1217
		800	55.2	924	24.8	3686	98.8	7312	196	11,858	318	23,206	622	42,094	1128
		1160	80	669	18	2655	71.2	5195	139	8651	232	16,897	453	29,923	802
1480	102	350	24.1	1078	28.9	4337	116	8781	235	13,685	367	26,861	720	50,507	1353
		500	34.5	1065	28.5	4273	115	8596	230	13,568	364	26,606	713	49,455	1325
		600	41.4	1049	28.1	4201	113	8416	226	13,392	359	26,246	703	48,428	1297
		800	55.2	994	26.6	3968	106	7887	211	12,746	342	24,950	668	45,396	1216
		1160	80	776	20.8	3082	82.6	6045	162	10,021	269	19,579	525	34,812	933

EZH and EZHSO Series

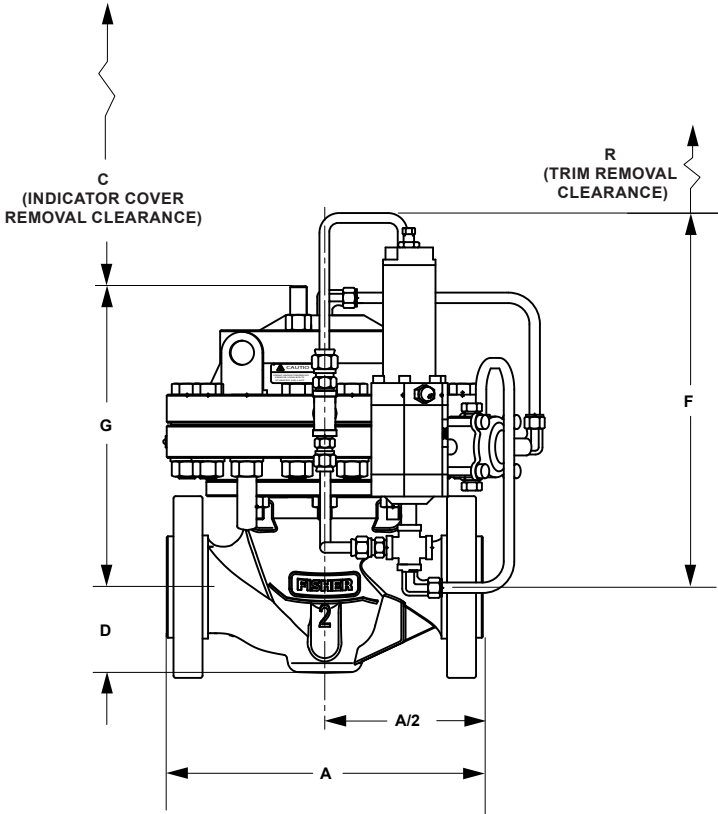
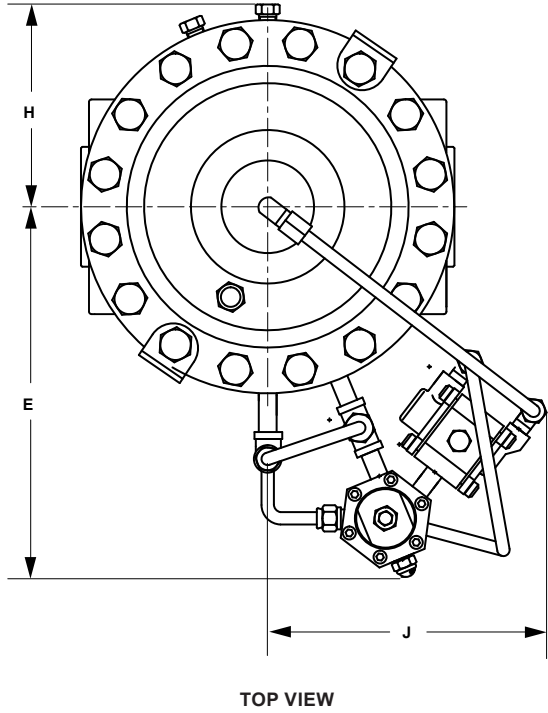

GE01592_B

Figure 10. Types EZH and EZHSO Dimensions

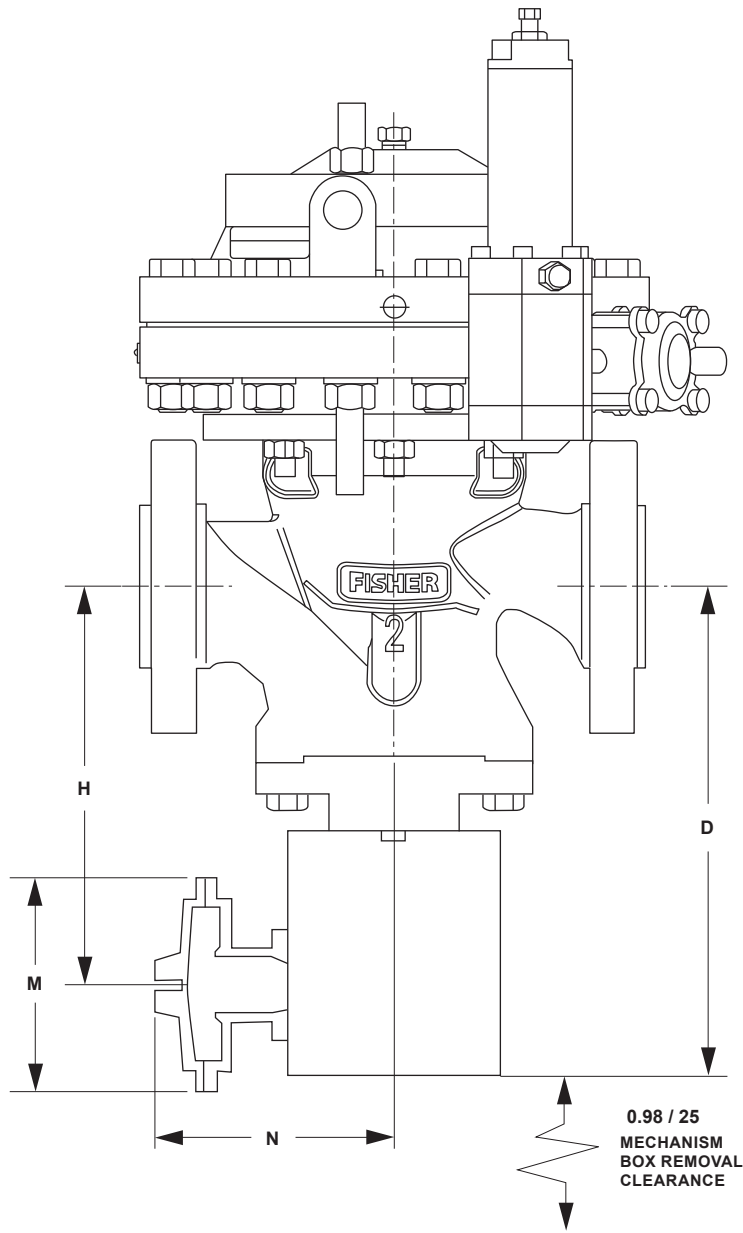

GE01592_A

IN. / mm

Figure 11. Type EZHOSX Dimensions

EZH and EZHSO Series

Table 19. Types EZH and EZHSO Dimensions

BODY SIZE, NPS / DN	DIMENSIONS, In. / mm											
	A				C	D (maximum)	E	F	G	H	J	R
	NPT or SWE	CL150 RF	CL300 RF	CL600 RF or BWE								
1 / 25	8.25 / 210	7.25 / 184	7.75 / 197	8.25 / 210	1.50 / 38.1	2.10 / 53	12.3 / 311	13.05 / 331	11.10 / 282	5.10 / 130	8.25 / 210	3.5 / 88.9
2 / 50	11.25 / 286	10.0 / 254	10.50 / 267	11.25 / 286	1.50 / 38.1	3.10 / 79	14 / 356	14.75 / 375	11.30 / 287	6.50 / 165	7.75 / 197	4.5 / 114
3 / 80	----	11.75 / 298	12.50 / 317	13.25 / 337	2.00 / 50.8	3.81 / 97	16 / 406	15.36 / 390	16.75 / 425	8.00 / 203	13.25 / 337	6.0 / 152
4 / 100	----	13.9 / 353	14.5 / 368	15.5 / 394	2.00 / 50.8	5.06 / 129	18.3 / 464	15.85 / 403	16.8 / 427	10.03 / 255	5.5 / 140	7.5 / 191
6 / 150	----	17.75 / 451	18.62 / 473	20 / 508	2.75 / 70	5.31 / 135	17 / 432	19.25 / 489	25 / 635	13 / 330	18 / 457	8.7 / 221
8 / 200	----	21.38 / 543	22.38 / 568	24 / 610	2.75 / 70	8.25 / 210	17 / 432	19.25 / 489	28.5 / 724	13 / 330	18 / 457	8.7 / 221
12 X 6 / 300 X 150	----	29 / 737	30.5 / 775	32.25 / 819	2.75 / 70	10 / 254	17 / 432	19.25 / 489	28.5 / 724	13 / 330	18 / 457	8.7 / 221

Table 20. Approximate Weights

BODY SIZE		FLANGED		NPT, SWE AND BWE		FOR TYPE OSX	
NPS	DN	lbs	kg	lbs	kg	lbs	kg
1	25	87	39	77	35	Add 17	Add 8
2	50	150	68	136	62	Add 30	Add 14
3	80	410	186	390	177	Add 41	Add 19
4	100	514	234	433	197	Add 57	Add 26
6	150	1460	662	1400	635	Add 74	Add 34
8	200	1875	850	1805	819	Add 97	Add 44
12 X 6	300 X 150	2050	930	1970	894	----	----

Table 21. Type EZHOSX Dimensions

BODY SIZE		DIMENSION WITH SLAM SHUT													
		D		H		M ⁽¹⁾				N					
						Diaphragm		Piston		Diaphragm		Piston		Bellows	
NPS	DN	In.	mm	In.	mm	In.	mm	In.	mm	In.	mm	In.	mm	In.	mm
1	25	12.0	305	9.8	249	6.4	163	2.8	71	6.9	175	8.0	203	8.8	224
2	50	13.0	330	10.4	264										
3	80	14.4	366	11.8	300										
4	100	16.8	427	13.6	346										
6	150	15.6	359	13.0	330										
8	200	22.8	579	18.7	475					8.3	211	9.2	243	9.9	253

1. Type 71 BMS with a diaphragm has an M dimension of 2.80 in. / 71 mm.

Ordering Information

Use the Specifications section on page 2 and carefully review the description to the right of each specification. Use this information to complete the Ordering Guide

on the following page. Specify the desired selection wherever there is a choice to be made. Then send the Ordering Guide to your local Sales Office.

Ordering Guide

Type and Body Material (Select One)

WCC Steel

- Type EZH (Spring-to-Close Version)***
- Type EZHSO (Spring-to-Open Version)***

LCC Steel

- Type EZHOSX (Spring-to-Close Version with Slam shut)***

Body Size (Select One)

- NPS 1 / DN 25***
- NPS 2 / DN 50***
- NPS 3 / DN 80***
- NPS 4 / DN 100***
- NPS 6 / DN 150***
- NPS 8 / DN 200***
- NPS 12 X 6 / DN 300 X 150***

End Connection Styles (Select One)

Types EZH and EZHSO Only

WCC Steel

- NPT (available for NPS 1 and 2 / DN 25 and 50 Body Sizes only)***
- CL150 RF***
- CL300 RF***
- CL600 RF***
- SWE (Available for NPS 1 and 2 / DN 25 and 50 Body Sizes only)**
- BWE**
- PN 16/40 (For NPS 1 and 2 / DN 25 and 50 Body Sizes only)**
- PN 25/40 (For NPS 3 / DN 80 Body Size only)**

Type EZHOSX Only

LCC Steel

- CL150 RF**
- CL300 RF**
- CL600 RF**

Main Valve Disk Material (Select One)

- Nitrile (NBR) (standard)***
- Fluorocarbon (FKM)***
- Polyurethane (PU)***

Pilot Type (Select One)

- Type PRX/120***
- Type PRX/120-AP***
- Type PRX/125 (monitor override pilot)***
- Type PRX/125-AP (monitor override pilot)***

Outlet Pressure Range (Select One)

Type PRX/120 or PRX/125

- 14.5 to 26 psig / 1.00 to 1.8 bar, Yellow***
- 23 to 44 psig / 1.6 to 3.0 bar, Green***
- 41 to 80 psig / 2.8 to 5.5 bar, Blue***
- 73 to 123 psig / 5.0 to 8.5 bar, Black***
- 116 to 210 psig / 8.0 to 14.5 bar, Silver***
- 203 to 334 psig / 14.0 to 23.0 bar, Gold***
- 319 to 435 psig / 22.0 to 30.0 bar, Aluminum***

Type PRX/120-AP or PRX/125-AP

- 435 to 1160 psig / 30.0 to 80.0 bar, Clear***

Whisper Trim™ Cage Construction (Optional)

[Not available to NPS 1 / DN 25 Body Size]

- Yes***

Type SA/2 Elastomer Material (Select One)

- Nitrile (NBR) (standard)***
- Fluorocarbon (FKM)***

Pilot Elastomer Material (Select One)

- Nitrile (NBR)/Polyurethane (PU) (standard)***
- Fluorocarbon (FKM)***

Travel Indicator (Select One)

- Yes***
- No***

- continued -

EZH and EZHSO Series

Ordering Guide (continued)

Main Valve Spare Parts Kit (Optional)

- Yes, send one disk parts kit to match this order.
- Yes, send one full parts kit to match this order.

Pilot Spare Parts Kit (Optional)

- Yes, send one spare parts kit to match this order.

Regulators Quick Order Guide	
***	Readily Available for Shipment
**	Allow Additional Time for Shipment
*	Special Order, Constructed from Non-Stocked Parts. Consult your local Sales Office for Availability.
Availability of the product being ordered is determined by the component with the longest shipping time for the requested construction.	

Specification Worksheet

Application:
 Specific Use _____
 Line Size _____
 Gas Type and Specific Gravity _____
 Gas Temperature _____
 Does the Application Require Overpressure Protection?
 Yes No If yes, which is preferred:
 Relief Valve Monitor Regulator Shutoff Device
 Is overpressure protection equipment selection assistance desired? _____

Pressure:
 Maximum Inlet Pressure (P_{1max}) _____
 Minimum Inlet Pressure (P_{1min}) _____
 Downstream Pressure Setting(s) (P_2) _____
 Maximum Flow (Q_{max}) _____
 Minimum Flow (Q_{min}) _____

Performance Required:
 Accuracy Requirements? _____

Other Requirements: _____

 Webadmin.Regulators@emerson.com

 Fisher.com

 Facebook.com/EmersonAutomationSolutions

 LinkedIn.com/company/emerson-automation-solutions

 Twitter.com/emr_automation

Emerson Automation Solutions

Americas

McKinney, Texas 75070 USA
 T +1 800 558 5853
 +1 972 548 3574

Europe

Bologna 40013, Italy
 T +39 051 419 0611

Asia Pacific

Singapore 128461, Singapore
 T +65 6777 8221

Middle East and Africa

Dubai, United Arab Emirates
 T +971 4 811 8100

D103081X012 © 2003, 2023 Emerson Process Management Regulator Technologies, Inc. All rights reserved. 07/23.

The Emerson logo is a trademark and service mark of Emerson Electric Co. All other marks are the property of their prospective owners. Fisher™ is a mark owned by Fisher Controls International LLC, a business of Emerson Automation Solutions.

The contents of this publication are presented for informational purposes only, and while every effort has been made to ensure their accuracy, they are not to be construed as warranties or guarantees, express or implied, regarding the products or services described herein or their use or applicability. All sales are governed by our terms and conditions, which are available upon request. We reserve the right to modify or improve the designs or specifications of such products at any time without notice.

Emerson Process Management Regulator Technologies, Inc does not assume responsibility for the selection, use or maintenance of any product. Responsibility for proper selection, use and maintenance of any Emerson Process Management Regulator Technologies, Inc. product remains solely with the purchaser.

