

PRICE®

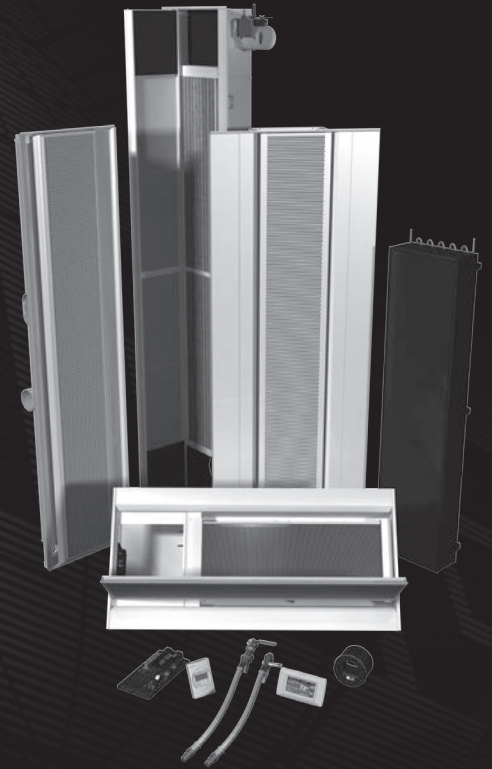

ACBH/ACBV ACTIVE CHILLED BEAM INSTALLATION MANUAL

Date: 05/12
Reference #: L-50

www.price-hvac.com

Installation Instructions

These installation instructions apply to the Price active chilled beams models ACBH and ACBV

Identification

ACBH:

- Horizontal heat exchanger (coil)
- Single, lateral air discharge with diffuser options
- Horizontal mounting



Figure 1

ACBV:

- Vertical heat exchanger (coil)
- Single, vertical air discharge with diffuser options
- Vertical mounting
- Optional drain pan and lint screen

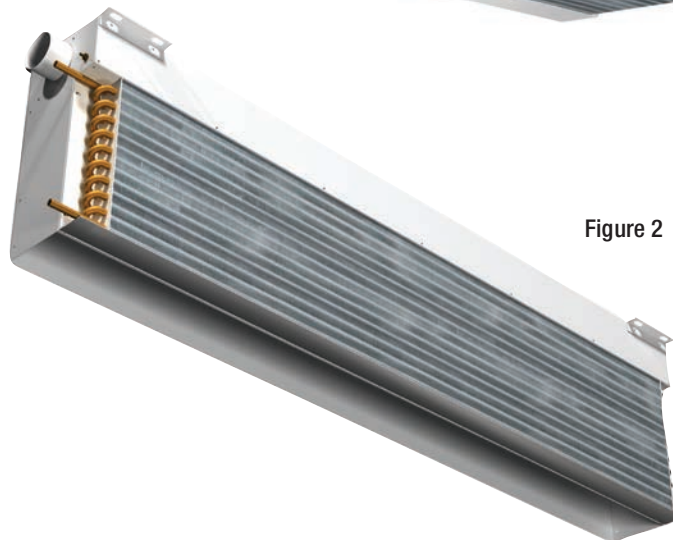

Figure 2

Handling

Units should only be handled by the case or mounting brackets. Handling by inlet or coil may cause damage.

Avoid introducing contaminants into the unit, keep the induction grille face, the duct inlet and the water connection piping covered at all times during the installation process. Selection of available plastic film option at order time will aid in this step.

To avoid smudging the unit while installing, the use of clean white cotton gloves is recommended

Units should be in a covered, dry location while waiting for installation. Location should be cleaned of excess dust before installation.

Installation

Determine where the beams should be located from project plans. The beam construction determines the beam performance.

Coordinate the beam's length, nozzle size, type of water coil connection, duct size, duct inlet location and air outlet configuration with the required location.

Installation hanger options

It is suitable to hang an ACBH or ACBV by the means listed below. The ACBH or ACBV hanging load shall only be supported from the building structure using the mounting brackets provided. Active beam should not be supported by suspended ceiling elements, duct or piping connections.

- Threaded rod – 3/8 inch
- Hanger wire
- Wire rope

Installation for bulkhead applications – ACBH

1. Unit (a) is shipped assembled. Return grilles and supply diffusers should be removed first.
2. Locate the unit to the position required and support unit with nuts if threaded rod is employed.
3. Unit is to be hung with coil in bottom-most configuration directly above perforated face.
4. Mounting brackets offer 1 inch flexible fore and aft positioning in locating threaded rod. Dual sided Unistrut or other speed rail as mounted above the beam offers side-to-side adjustment and flexibility in locating threaded rod.
5. Initially mount the beam approximately 1-2 inch above the final ceiling level.
6. Install the ceiling structure or framing then lower beam to final level.
7. Complete connections to water coil and duct work.
8. Sheet metal connecting beam to discharge diffuser frame is supplied by others.
9. Complete air and water connections and balance both systems prior to finishing ceiling or ensure access by adjacent ceiling panel.
10. Finish ceiling allowing for openings to accommodate discharge and return frames and grilles
11. Locate discharge frame (c) on discharge duct and secure to unit frame with supplied fasteners. Locate discharge grille (b) within discharge frame and secure with supplied screw fasteners.
12. Locate return grille frame (e) on coil cover and secure to unit frame with supplied fasteners. Locate return grille (d) within return grille frame and secure with supplied quarter-turn fasteners.

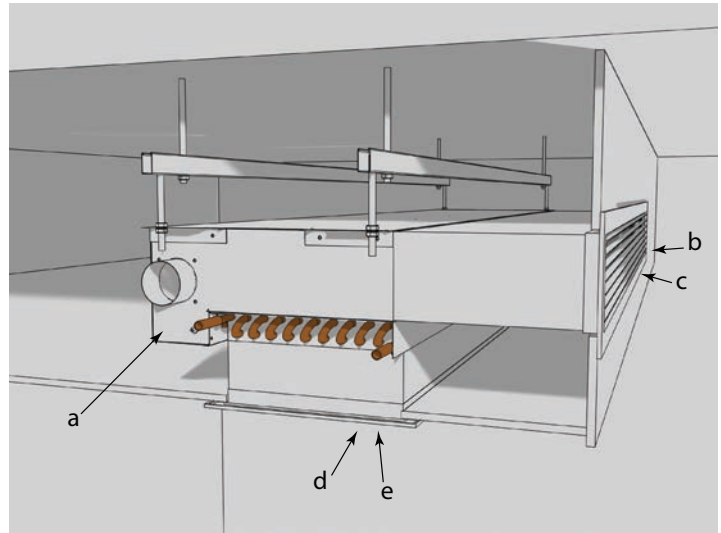

Figure 3

Installation for recessed ceiling applications – ACBH and ACBV

1. Locate the unit to the position required and support with nuts if threaded rod is employed.
2. ACBH Unit is to be hung with coil in bottom-most configuration or directly above perforated face if one is installed. ACBV is to be hung with coil in vertical position.
3. Mounting brackets offer 1 inch flexible fore and aft positioning in locating threaded rod. Dual sided Unistrut or other speed rail as mounted above the beam offers side-to-side adjustment and flexibility in locating threaded rod.
4. Initially mount the beam approximately 1-2 inches above the final ceiling level.
5. Install the ceiling structure or framing then lower beam to final level.
6. It is recommended to complete air and water connections and balancing prior to finishing ceiling.
7. Drain pan or filter options for ACBV are factory installed if selected as an option for a beam configuration. Ensure drain pan is free from debris and that connection will permit flow of condensate. Connect any condensate piping or pumping equipment, supplied by others following manufacturers installation instructions.
8. If applicable, locate discharge frame on discharge duct and secure to unit frame with supplied fasteners. Locate discharge grille within discharge frame and secure with supplied screw fasteners.

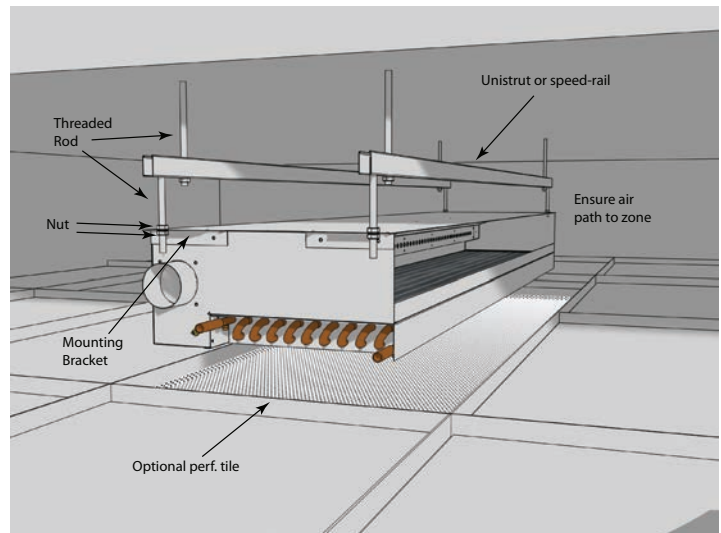
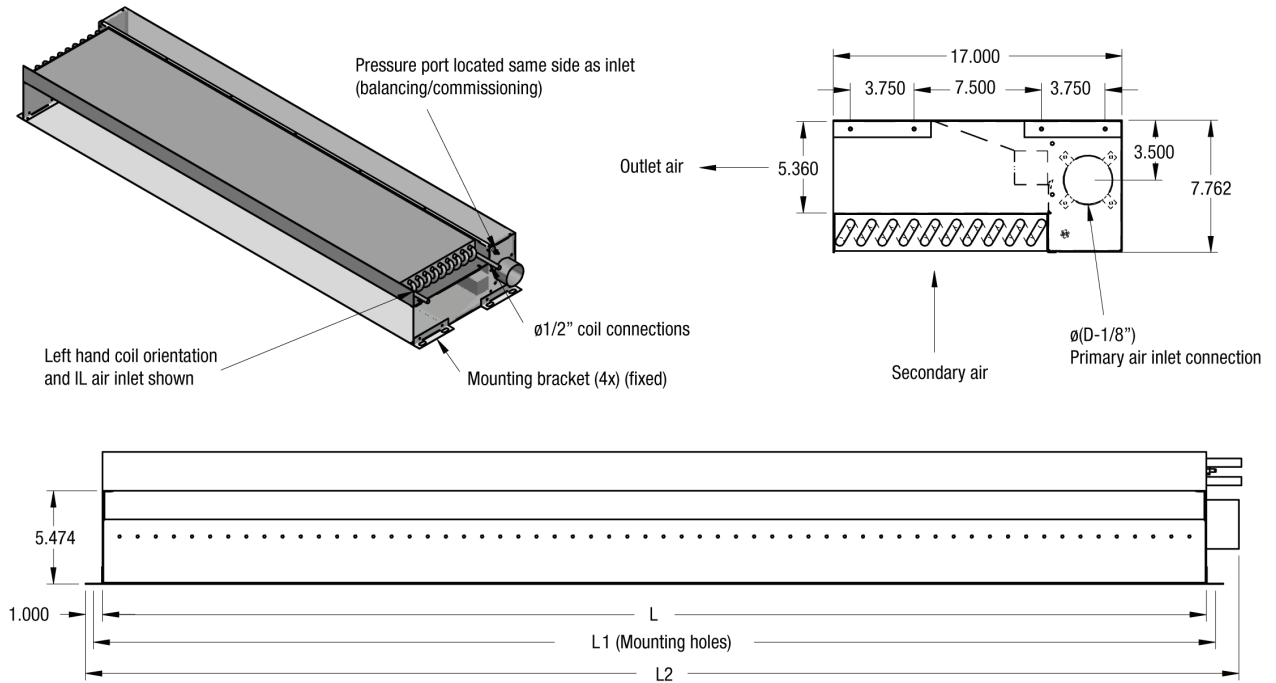

Figure 4

Installation Instructions

ACBH - Active Chilled Beam Horizontal



NOM length	Inlet size (L)	Mounting (L1)	Overall size (L2)
24	24.000 (610)	25.000 (635)	29.000 (737)
36	36.000 (914)	37.000 (940)	41.000 (1041)
48	48.000 (1219)	49.000 (1245)	53.000 (1246)
60	60.000 (1524)	61.000 (1549)	64.000 (1625)
72	72.000 (1851)	73.000 (1854)	75.000 (1905)

Figure 5

Length (ft)	ACBH/ACBV unit		ACBH face and diffuser options			ACBV diffuser options	
	Dry weight (lb)	Total wet weight (lb)	Perforated face weight increase (lb)	520 grille weight increase (lb)	620 grille weight increase (lb)	LV-1 weight increase (lb)	JS-210 weight increase (lb)
2	23	26	3	1	1	1	1
3	34	38	5	3	2	2	3
4	44	49	6	6	4	5	7
5	44	49	8	9	5	7	10
6	65	72	9	11	6	9	13

Water Connections

Recommended water connections:

- Sweat, female NPT, quick-connect for 0.5 inch (nominal) Copper tube.

Before connecting beams to the water system, flush and drain the main system piping to remove contaminants from the construction process.

Pressure test the water system for leaks. Isolate and repair leaks.

Move water through the hydronic system at or above 0.5 gpm to assist purging air from the beams. If 0.5 gpm per beam is not normally available, shut off flow through other beams to divert more water through the beams being flushed. Air vents are integrated at the return side of coil connections to purge air. Ensure system air traps are operating as required if installed.

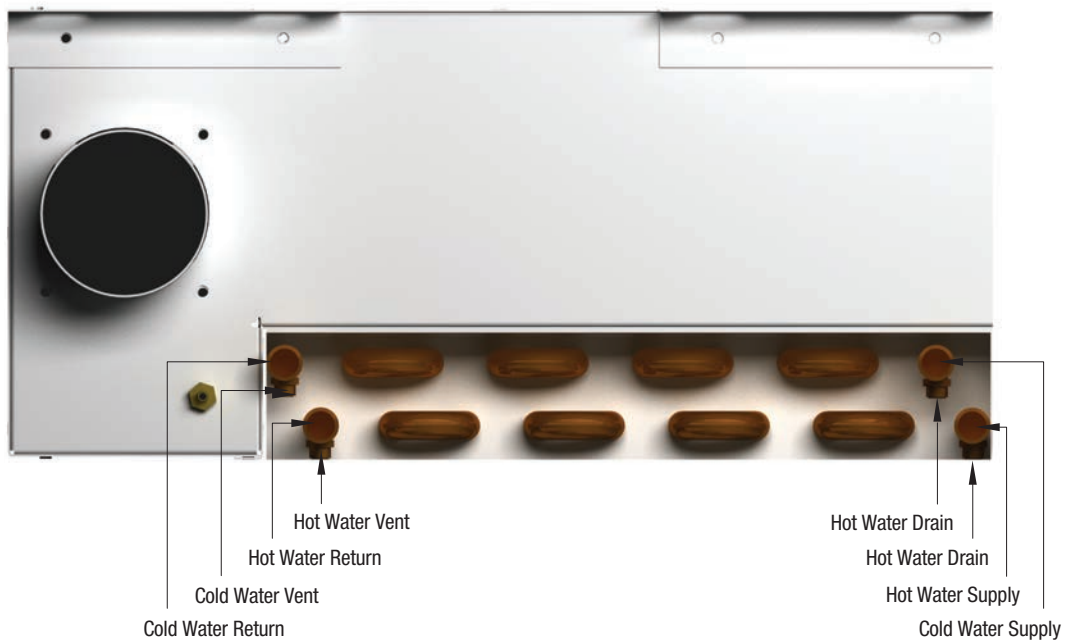

Figure 6

Air Connections

Ensure an airtight connection between the air supply duct and the active beam. Duct connections are recommended to meet SMACNA class B up to 2 in w.g.

Air connections should ideally have straight duct sections three duct diameters long upstream of the air inlet although bends in the duct are permitted close to the air inlet. Only straight ductwork connections are expected to yield a reliable duct traverse measurement.

Air Balancing

Measure pressure drop across the active beam connecting a differential pressure measurement device to the brass pressure port included on the beam.

Adjust branch balancing damper to match the schedule pressure drop with the measurement. Balancing damper to be supplied by others. Contact Price application engineering for high altitude balancing charts.



Figure 7

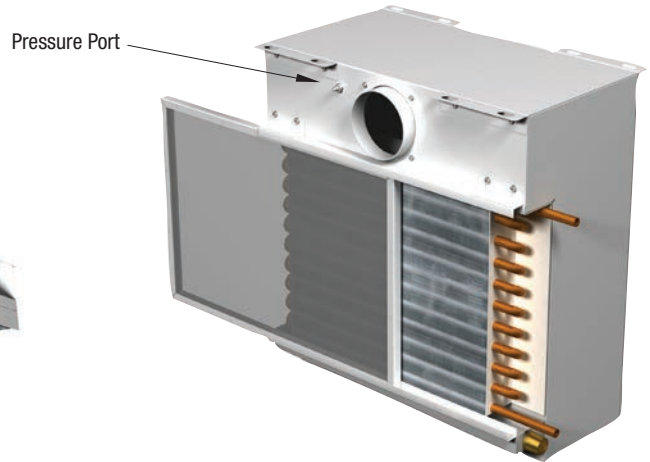

Figure 8

Airflow Calibration Chart for ACBH / ACBV

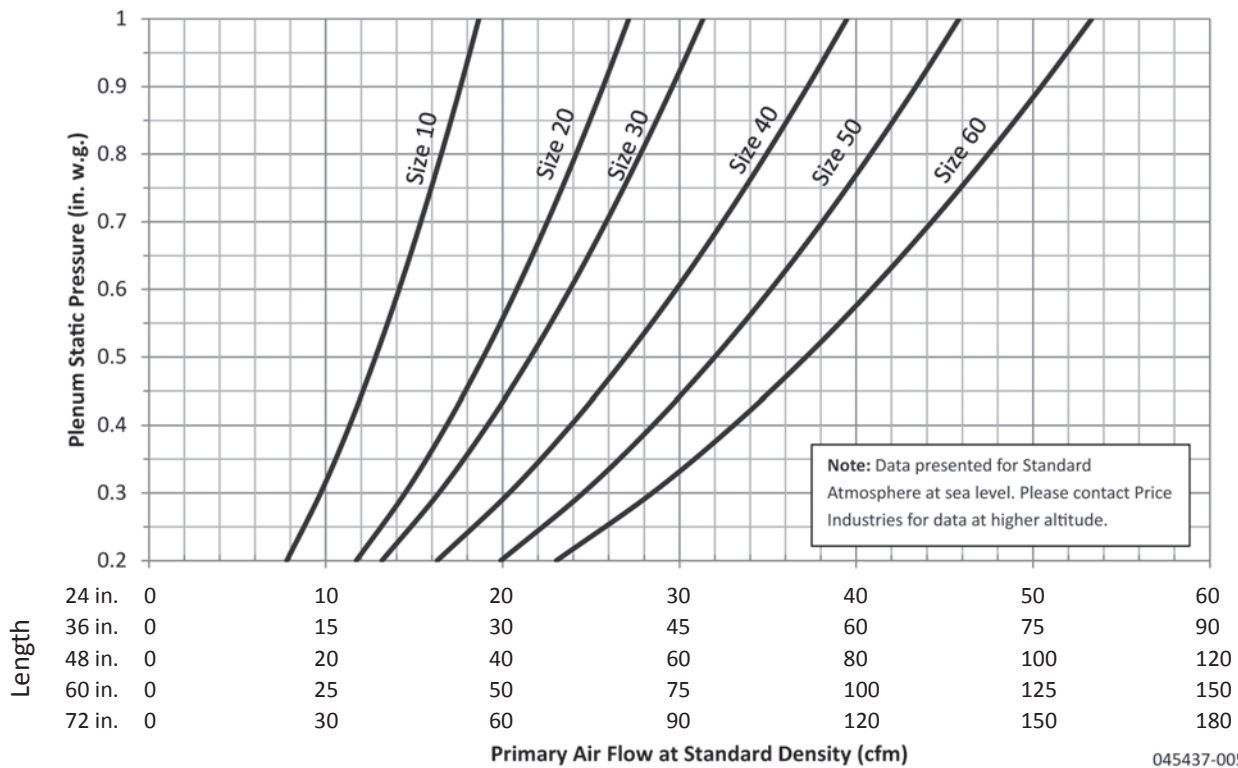

Figure 9

Water balancing

The active beam does not ship with balancing values as standard. This instructions offered here are guidelines for proper operation.
 Manual:

- Adjust balancing valves according to design drawings and valve schedule.

Pressure Independent:

- Ensure correct pressure independent valves are installed according to design drawings and valve schedule

Maintenance

Maintain water conditions which prevent corrosion of copper tubing and ensure that safeguards against air accumulation through leaks or oxygen diffusion in system piping are functioning.

Vacuum coils with soft bristle brush as required. Typically 3-5 years.

If included in the system design check the condensate sensor(s) or humidity sensor(s) according to sensor manufacturer’s methods and schedule.

Interpretation of Beam Tag

- All beams come shipped with a tag affixed to the beam. This tag should be checked to ensure that the beam is placed in the proper location, and contains the correct options.



Figure 10

PRICE®



2975 Shawnee Ridge Court
Suwanee, Georgia USA 30024
Ph: 770.623.8050 Fax: 770.623.6404

- U.S. Head Office
- Price Technical Center
- Atlanta Manufacturing Facility



1290 Barrow Industrial Parkway
Winder, Georgia USA 30680-5704

- Atlanta Manufacturing Facility



999 North Thornton Road
Casa Grande, Arizona USA 85222-3809

- Price Technical Center West
- Phoenix Manufacturing Facility



638 Raleigh Street
Winnipeg, Manitoba Canada R2K 3Z9
Ph: 204.669.4220 Fax: 204.663.2715

- Canadian Head Office
- Price Research Center North
- International Sales Office
- Winnipeg Manufacturing Facility



130B Pippin Road
Vaughan, Ontario Canada L4K 4X9

- Toronto Manufacturing Facility

Product Improvement is a continuing endeavour at Price. Therefore, specifications are subject to change without notice. Consult your Price Sales Representative for current specifications or more detailed information. Not all products may be available in all geographic areas.

All goods described in this brochure are warranted as described in the Limited Warranty shown at the web site www.price-hvac.com.

The Price catalog is available online at www.price-hvac.com

