

Belgacom Twist 619

User manual



3111 285 50201

belgacom

Table of contents

1	Important	4	4.1.8	Enter a Dialing Pause	24
1.1	Power requirements	4	4.2	Answer a call	24
1.2	Using GAP standard compliance	5	4.2.1	Handsfree answering	24
1.3	Recycling and disposal	5	4.3	End a call	24
2	Your phone	7	5	Use more of your phone	25
2.1	What's in the box	7	5.1	Switch the handset off/on	25
2.2	Overview of your phone	8	5.2	Keypad lock/unlock	25
2.3	Display icons and Messages	10	5.3	Text or number entry	25
2.4	Overview of the base station	12	5.4	Call in progress	25
3	Getting started	13	5.4.1	Adjust earpiece or speaker volume	25
3.1	Connect the base station	13	5.4.2	Mute/Unmute microphone	25
3.2	Wall mounting the base	13	5.4.3	Activate/Deactivate loudspeaker mode	26
3.3	Install your phone	14	5.5	Chain dialing	26
3.3.1	Install battery	14	5.6	Using your Phonebook	26
3.3.2	Charge battery	15	5.6.1	Store a contact in the phonebook	26
3.4	Configuration of your Twist 619 telephone	15	5.6.2	Access phonebook	26
3.5	Menu structure	16	5.6.3	Modify a phonebook entry	27
4	Using your phone	23	5.6.4	Select phonebook melody	27
4.1	Make a call	23	5.6.5	Delete a phonebook entry	28
4.1.1	Predialling	23	5.6.6	Delete all phonebook entries	28
4.1.2	Direct dialling	23	5.6.7	Direct access memories - PhoneMail	28
4.1.3	Call from redial list	23	5.7	Using the Redial list	29
4.1.4	Call from the call log	23	5.7.1	Access Redial list	29
4.1.5	Call from the phonebook	23	5.7.2	View redial number details	29
4.1.6	Call from the phonebook while already on the phone	23	5.7.3	Save a redial number into the phonebook	29
4.1.7	Call using Direct Access Memory	24	5.7.4	Delete a redial number	29
			5.7.5	Delete all redial numbers	30

5.8	Call waiting	30	6.8	Deactivate/Activate Auto Hang-Up	37
5.9	Using the Call log	30			
5.9.1	Access the Call log	30	7	Advanced settings	37
5.9.2	Save call list entry into the phonebook	31	7.1	Easy Call	37
5.9.3	Delete a call list entry	31	7.1.1	Set Easy Call to On or Off	38
5.9.4	Delete all call list entries	31	7.1.2	Set Easy Call number	38
5.10	Using the Intercom	31	7.2	Auto Conference	38
5.10.1	Intercom another handset	31	7.3	Call Barring	38
5.10.2	Transfer an external call to another handset	32	7.3.1	Set Call Barring Mode	39
5.10.3	Answer an external call during intercom	32	7.3.2	Set a Call Barring number	39
5.10.4	Switch between an internal and external call	32	7.4	XHD Sound	39
5.10.5	Establish a three-party conference call	32	7.5	Change PIN	40
5.11	Paging	33	7.6	Registration	40
5.12	Clock and Alarm settings	33	7.6.1	Easy registration	41
5.12.1	Set Date and Time	33	7.7	Unregister	41
5.12.2	Set Time and Date Format	33	7.8	Reset Unit	41
5.12.3	Set Alarm	34	7.9	Change Flash time	42
5.12.4	Set Alarm Tone	34	7.10	Set First Ring Detection	42
			7.11	Default Settings	42
6	Personal settings	35	8	Network Services	43
6.1	Change the Handset Name	35	8.1	Call Forward	43
6.2	Handset Tones	35	8.1.1	Change Call Forward Activation Codes	44
6.2.1	Set the Ring Volume	35	8.1.2	Change Call Forward Deactivation Code	44
6.2.2	Set the Ring Tones	35	8.2	Call Forward when Busy	44
6.2.3	Activate/Deactivate Key Beep	36	8.2.1	Change Call Forward when Busy Activation Codes	45
6.3	Change the Display Language	36	8.2.2	Change Call Forward when Busy Deactivation Code	45
6.4	Select the Display Wallpaper	36	8.3	Call Forward when Unanswered	45
6.5	Select the Color Theme	36	8.3.1	Change Call Forward when Unanswered Activation Codes	46
6.6	Set the Display Contrast	37			
6.7	Set the Backlight Time	37			

8.3.2	Change Call Forward when Unanswered Deactivation Code	46	10	Telephone answering machine (TAM)	53
8.4	Phonemail	46	10.1	Playing Messages	54
8.4.1	Access Phonemail	46	10.1.1	Playback of messages via handset	54
8.4.2	Set Phonemail Number	47	10.1.2	Functions available during playback	54
8.5	Call Return	47	10.2	Delete all messages	54
8.5.1	Access the Call Return Service	47	10.3	Turn the Answering Machine On/Off	54
8.5.2	Set Call Return Service Number	47	10.4	Play, Record, or Delete an Outgoing Message	55
8.6	Cancel Call Back	47	10.5	Set the Answer mode	55
8.6.1	Call the Cancel Call Back Number	48	10.6	Answering Machine Settings	55
8.6.2	Set the Cancel Call Back Number	48	10.6.1	Ring Delay	55
			10.6.2	Remote Access	56
9	Short Message Service (SMS)	48	10.6.3	Handset Screening	57
9.1	Write and Send an SMS	48	10.6.4	Setting the Outgoing Message Language	57
9.2	Inbox	49	11	Technical data	58
9.2.1	Read SMS Messages (Check Inbox)	49	12	Frequently asked questions	58
9.2.2	Reply to an SMS Message	50	12.1	Connection	58
9.2.3	Forward an SMS Message	50	12.2	Set-up	59
9.2.4	Save the Number of an SMS Message	50	12.3	Sound	59
9.2.5	Delete an SMS Message	50	12.4	Product behaviour	59
9.2.6	Delete all SMS Messages	51	13	Declaration of Conformity	62
9.3	Drafts	51	14	INDEX	63
9.3.1	Open a Draft	51			
9.3.2	Send a Draft	51			
9.3.3	Edit a Draft	51			
9.3.4	Delete a Draft	52			
9.3.5	Delete all Drafts	52			
9.4	Settings	52			
9.4.1	SMS Reception	52			
9.4.2	SMS Centre	52			
9.4.3	Default Centre	53			

1 Important

Take time to read this user manual before you use your phone. It contains important information and notes regarding your phone.

1.1 Power requirements

- This product requires an electrical supply of 100-240 volts AC. In case of power failure, communication can be lost.
- The Electrical network is classified as hazardous. The only way to power down the charger is to unplug the power supply from the electrical outlet. Ensure that the electrical outlet is always easily accessible.
- The voltage on the network is classified as TNV-3 (Telecommunication Network Voltages), as defined in the standard EN 60-950.

Warning

To avoid damage or malfunction:

- Do not allow the charging contacts or the battery to come into contact with metal objects.
- Do not open your product as you could be exposed to high voltages.
- Do not allow the charger to come into contact with liquids.
- Never use any other battery than the one delivered with the product or recommended by Belgacom: risk of explosion.

- Always use the cables provided with the product.
- Handsfree activation could suddenly increase the volume in the earpiece to a very high level: make sure the handset is not too close to your ear.
- This equipment is not designed to make emergency calls when the power fails. An alternative has to be made available to allow emergency calls.
- Do not expose the phone to excessive heat caused by heating equipment or direct sunlight.
- Do not drop your phone or allow objects to fall on your phone.
- Do not use any cleaning agents containing alcohol, ammonia, benzene, or abrasives as these may harm the set.
- Do not use the product in places where there are explosive hazards.
- Do not let small metal objects come into contact with the product. This can deteriorate audio quality and damage the product.
- Active mobile phones in the vicinity may cause interference.
- Use only with provided batteries.
- Rechargeable batteries information
Ni-MH battery, AAA × 2, 1.2V, 600mAh
- Use only with provided power supply.
- Power supply information for base station
Input: AC100-240V/0.3A, 50Hz/60Hz
Output: DC6V/0.5A
JOD-SWR-07342
JODEN

- Power supply information for charger (multihandset pack only)
Input: AC100-240V/0.3A, 50Hz/60Hz
Output: DC6V/0.21A
JOD-SWR-07343
JODEN
- Risk of explosion if battery is replaced by an incorrect type.
Dispose of used batteries according to the instructions.

About operating and storage temperatures:

- Operate in a place where temperature is always between 0 and 35°C (32 to 95°F).
- Store in a place where temperature is always between -20 and 70°C (-4 to 158°F).
- Battery life may be shortened in low temperature conditions.

1.2 Using GAP standard compliance

The GAP standard guarantees that all DECT™ GAP handsets and base stations comply with a minimum operating standard irrespective of their make. Your handset and base station are GAP compliant, which means the minimum guaranteed functions are: register a handset, take the line, receive a call and dial. The advanced features may not be available if you use a handset other than a Twist619 with your base station. To register and use your Twist619 handset with a GAP standard base station of a different make, first follow the procedure described in the

manufacturer's instructions, then follow the procedure described in section 7.6. To register a handset of another make to the Twist619 base station, place the base station into registration mode, then follow the procedure in the manufacturer's instructions.

1.3 Recycling and disposal

Disposal instructions for old products: The WEEE directive (Waste Electrical and Electronic Equipment Directive; 2002/96/EC) has been put in place to ensure that products are recycled using the best available treatment, recovery and recycling techniques to ensure human health and high environmental protection. Your product is designed and manufactured with high quality materials and components that can be recycled and reused.

Do not dispose of your old product in your general household waste bin. Inform yourself about the local separate collection system for electrical and electronic products marked by this symbol.



Use one of the following disposal options:

- Dispose of the complete product (including its cables, plugs and

accessories) in the designated WEEE collection facilities.

- If you purchase a replacement product, hand your complete old product back to the retailer. He should accept it as required by the WEEE directive.

Disposal instructions for batteries:

Batteries should not be disposed of with general household waste.



Packaging information:

Belgacom has marked the packaging with standard symbols designed to promote the recycling and appropriate disposal of your eventual waste.



A financial contribution has been paid to the associated national recovery & recycling system.



The labeled packaging material is recyclable.

2 Your phone

Congratulations on your purchase and welcome to Belgacom!

2.1 What's in the box



Handset

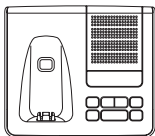

**Base Station
with bracket**



Battery door



**2 AAA rechargeable
batteries**

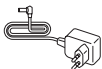

Power supply



Line cord*



User manual



Belgium adapter

Note

* You may find in the box the line adaptor delivered separately from the line cable. **In this case, you have to connect the line adaptor to the line cord first before plugging the line cord to the line socket.**

2.2 Overview of your phone

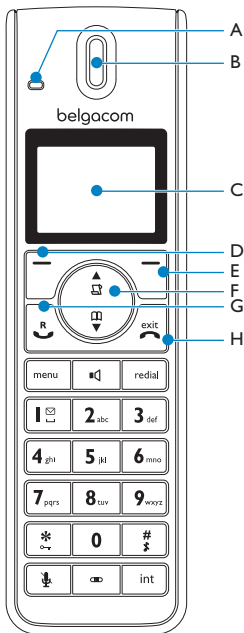

A Event LED

The event LED on your handset blinks when there is a new message recorded on your telephone answering machine. If you have subscribed to Caller Line Identification, the event LED also blinks when there is a new call, a new SMS or a new voice mail message.

B Earpiece

C Display

See section 2.3 for an overview of the display icons.

D Select key

Select the function displayed on the screen or go to the next lower level in a menu. Also used to confirm entries (for example when setting date and time).

E Back/Clear key

Press to clear (delete) a character or number when making an entry. Long press to clear all.

When navigating menus, press to move to the previous higher menu level (**Back** is displayed).

F Navigation keys

In idle mode: Scroll up to access the Call log and scroll down to access the Phonebook.

During a call: Scroll to increase or decrease earpiece and speaker volume.

Editing and entry: Move to the previous character or next character .

In other modes: Scroll up and down a menu list or go to the previous or next record in the Phonebook, Redial list, or Call log.

G Talk key

In idle mode: Make an external call or answer an incoming external or internal call.

During a call: Activate the recall function.

In other modes: Dial the selected number in the Phonebook, Redial list, or Call log.

H Hang-up key

In idle mode: Long press (5 seconds) to switch off the handset.

When the handset is switched off: Long press (1 second) to switch it on.
During a call: Hang up a call.
In other modes: Press to return to idle mode.

I Menu key 

In idle mode: Go to the main menu.



J Redial key 

Access the Redial list in idle mode.

K Loudspeaker key 

In idle mode: Turn on the loudspeaker and dial the number. Answer an incoming call using handsfree mode.
During a call: Toggle the loudspeaker on/off.

L Number keys

Use to dial numbers and write characters.
With keys  to , a long press dials one of your direct memory access numbers.

M */Keypad lock key 

In idle mode: Long press to lock/ unlock keypad.

Predialling or editing: Press to enter a “*”.

N #/Ringer on/off & Pause key 

In idle mode: Long press to turn the ringer on/off.

Dialling or editing: Long press to insert a pause (during predialling) and short press to insert a “#”.

Editing: Short press to switch upper/ lower case.

O Mute key 

When off hook: Deactivate/activate the microphone.

P Call transfer key & Intercom key 

In idle mode: Initiate an internal call.

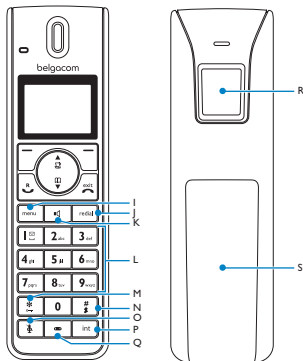

During a call: Short press to hold the line and page another handset. Long press to set up a conference between an external call and two handsets.

Q Microphone

R Loudspeaker

 **Warning**

Handsfree activation can suddenly increase the volume of the earpiece to a very high level. Make sure the handset is not too close to your ear.

S Battery door

2.3 Display icons and Messages



Indicates that the battery is fully charged. This icon blinks during charge and when the battery is low.



When the icon is empty the battery is practically discharged.

Note

If **Warning Batt** flashes together with a blinking battery icon, batteries of the wrong type are installed in the handset. Replace with batteries of the correct type.



Blinks when there is an incoming call. Steady ON during a call.



Blinks when there is new Phonemail or SMS messages in the SMS box. Steady ON when there are old received SMS messages in the SMS box.



Indicates new and missed calls in the call log records. Blinks when there are missed calls.



Appears when the alarm clock is activated. Blinks when the alarm time comes.



Appears when the loudspeaker is activated.



Appears when the ringer is off.



Steady on when the answering machine is on. Blinks when messages have been received by the answering machine; blinks rapidly when answering machine memory is full.



Indicates that the handset is registered and within range of the base station. Icon blinks when the handset is out of range or is searching for a base.

Select/
OK

Select appears when in menu mode. Press the key directly below to move to the next menu level or to confirm a selection.

OK appears to request confirmation of an operation. Press the key directly below to confirm.



Indicates that more options are available in a scroll list, or that you can adjust the volume.

Back/ **Back** appears when in menu mode. Press the key directly below to return to the previous menu level.

Clear appears when making an entry. Press the key directly below to clear (delete) a character or number when making an entry. Long press to clear all.

2.4 Overview of the base station

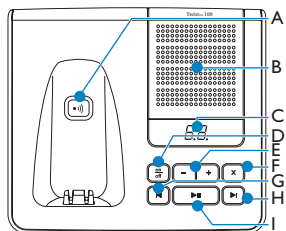

A Paging key (•||)

Page handset.

Long press to start registration procedure.

B Speaker

C Message counter

Steady ON: shows the number of old messages.

Blinking: Shows the number of new messages only.

Two horizontal bars "--" blinking: Indicates that the answering machine memory is full.

Also shows the base volume level when adjusting the volume.

D On/Off key (on/off)

Short press to switch the answering machine on/off.

E Volume keys (- +)

Increase or decrease the speaker volume. There are 5 volume levels during playback. There are 5 volume levels plus OFF during idle mode and call screening.

F Delete key (x)

Short press to delete the current message during message playback. Long press (2 seconds) when in idle mode to delete all old messages. (New messages will not be deleted.)

G Previous key (◀)

Go to previous message if pressed within 1 second of current message playback. Replay current message if pressed after 1 second of current message playback.

H Next key (▶)

Skip to the next message during message playback.

I Play/Stop key (▶|)

Play phone messages (the first recorded will be played first). There will be a short beep between messages and a double beep when all messages have been played.

Stop message playback.

3 Getting started

3.1 Connect the base station

- 1 Place the base station in a central location near the telephone line socket and electricity socket.
- 2 Connect the line cord and the power cable to their corresponding connectors at the back of the base station.

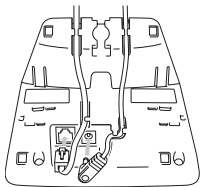

- 3 Connect the other end of the line cord and power cable to their respective sockets.

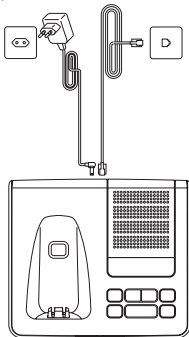

Warning

Avoid placing the base station too close to large metal objects such as filing cabinets, radiators or electrical appliances. This can impair the range and sound quality. Buildings with thick internal and external walls may impair transmission of signals to and from the base.

Warning

Power is applied when the power adaptor is plugged into the unit and connected to the electricity socket. The only way to power down the unit is to unplug the power adaptor from the electricity socket. Therefore, ensure that the electricity socket is easily accessible. The power adaptor and telephone line cord have to be connected correctly, as incorrect connection could damage the unit. Always use the telephone line cord supplied with the unit. Otherwise, you may not get a dial tone.

3.2 Wall mounting the base

The base is designed to support wall mounting. To wall mount the base, follow the instructions below.

- 1 Remove the bracket from the back of the base station by ① pressing the two latches on the inside of the bracket and ② rotating the bracket outward.

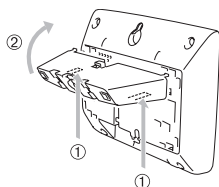

- 2** Turn the bracket around.

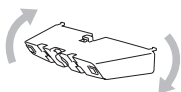

- 3** Attach the bracket to the opposite side of the base station.

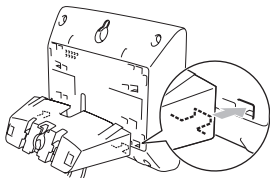

- 4** Insert screws (not included) into the wall.
- 5** Align the mounting hole on the back of the base with the screws on the wall.

- 6** Slide the base down into place.

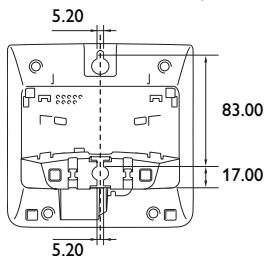

3.3 Install your phone

Before using the handset, the batteries have to be installed and fully charged.

Warning

When the batteries are inserted for the first time, the unit will not be able to start normally due to the low battery. You must charge the batteries on the base station before you can use the handset.

3.3.1 Install battery

Warning

Always use AAA rechargeable batteries supplied with your unit. If alkaline batteries are used instead of rechargeable batteries, “**Warning Batt**” will show on the display and the battery icon will blink quickly.

- 1 Slide out the battery cover.

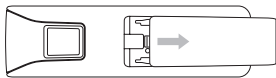

- 2 Place the batteries in the correct polarity as indicated and replace the cover.

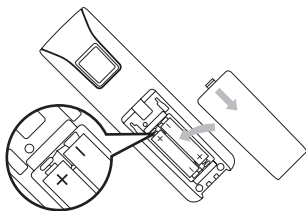



3.3.2 Charge battery

Warning

The handset must be charged for at least 24 hours before using it for the first time. When the battery level becomes low, the low battery sensor warns you by blinking the battery icon. If this occurs during a conversation, an alert tone sounds to inform you that the battery is low. If the battery level becomes exceedingly low, the phone automatically switches off shortly after the icon starts blinking and any function in progress will not be saved.

- 1 Place the handset on the charging cradle of the base station. A beep is emitted if the handset is placed correctly.

- 2 The battery icon  on the display blinks during charge.
- 3 The battery icon  becomes steady when the handset is fully charged.







Note

Optimal battery life is reached after 3 cycles of complete charging (over 15 hours) and discharging, allowing approximately 12 hours of talk-time and 150 hours of stand-by time. The indoor and outdoor range of the phone is up to 50 metres and 300 metres respectively. When the handset moves beyond the operation range, the antenna icon  will blink.

Tip







When you reach the range limit the conversation may become crackly. Move closer to the base.



3.4 Configuration of your Twist 619 telephone



In order to use more easily your phone, we suggest you to modify the menu language (Default language is English). Press  in idle mode, scroll with  to **Personal set**, press  **Select**, scroll with  to **Language**, press  **Select**, and scroll through the various languages until you reach your preferred one, and press  **Select** to confirm.

3.5 Menu structure

The Twist619 has seven menus as shown in the following table.

	Menu Name	Icon
1	Phonebook	
2	Personal Settings	
3	Clock and Alarm	
4	Advanced Settings	
5	Network Services	
6	SMS	
7	Answer Machine	

Press the menu key  to enter menu mode. Use navigation keys  to navigate within the menus and all submenus.

Press  **Select** to enter the next lower menu level. Press  **Back** to go to the previous menu level.

The charts below show the menu trees of your phone.

Phonebook

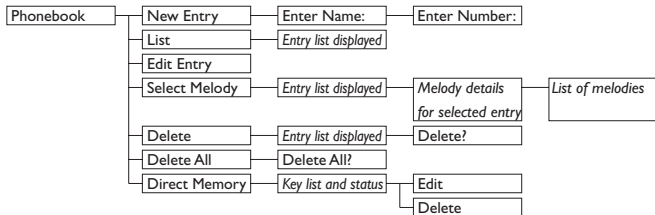

Personal Settings

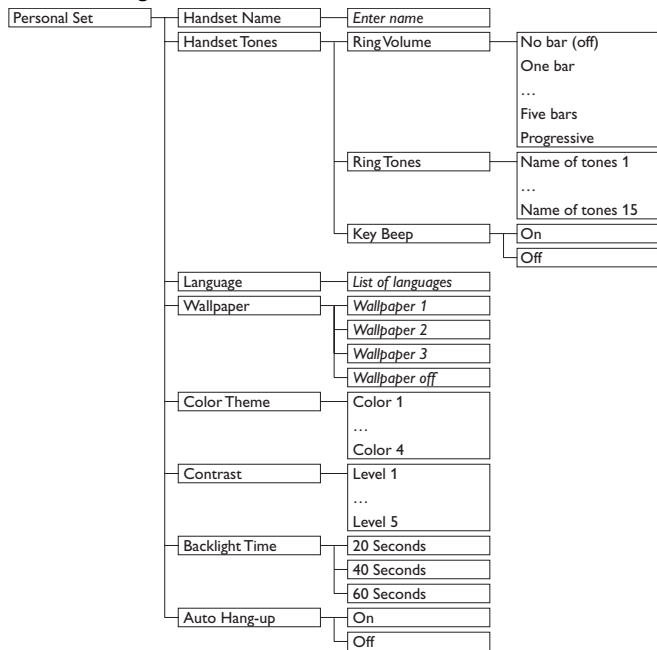

Clock and Alarm

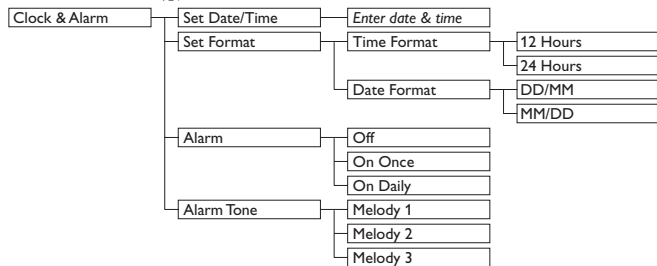

Advanced Settings

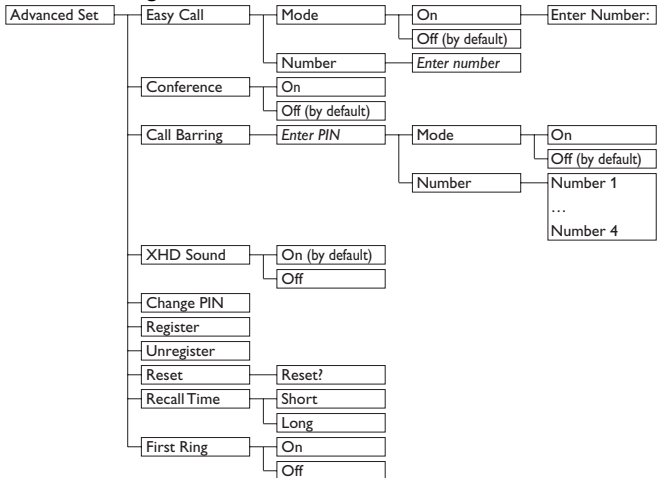

Network Services

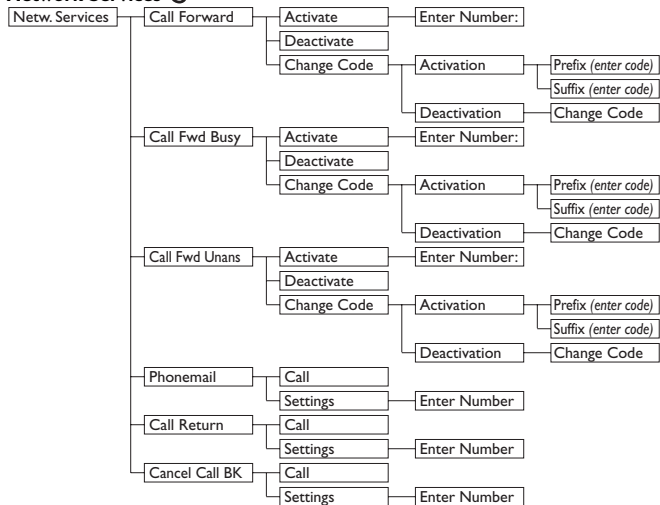

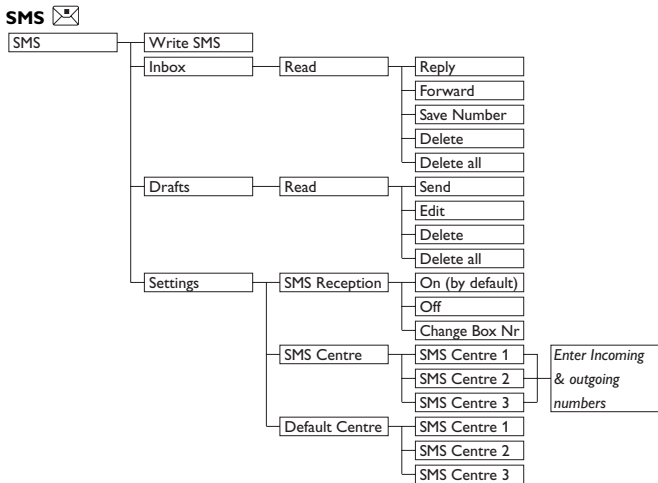

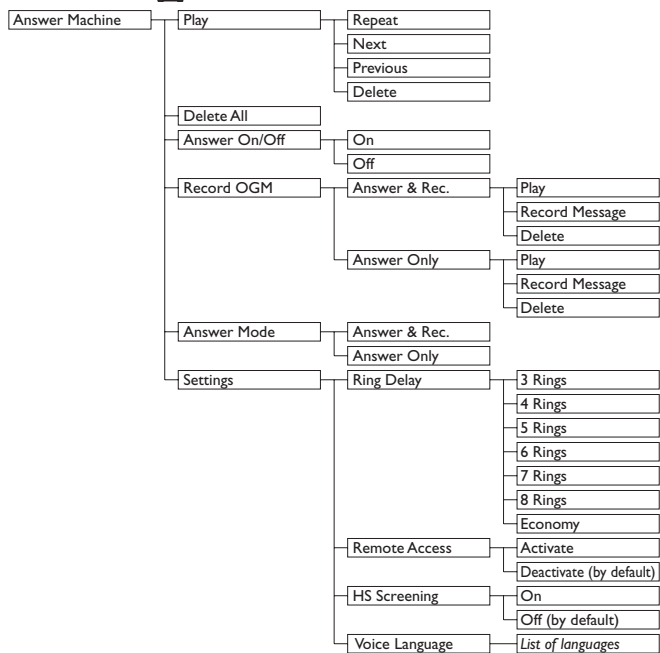

Answer Machine





4 Using your phone

4.1 Make a call



4.1.1 Predialling

- 1 Enter the number. (A maximum of 24 digits including * and # are allowed. Press  **Clear** to delete the last digit.) Or long press to delete all.
- 2 Press .
 - The call is initiated.





4.1.2 Direct dialling

- 1 Pick up the handset and press . (Or press  to start a call in speaker mode.)
- 2 Dial the number.
 - The call is initiated.

4.1.3 Call from redial list

- 1 Press  in idle mode.
- 2 Scroll  to an entry in the redial list.
- 3 Press .
 - The call is initiated.



Note

- You can also press  first and then press  **Redial** to enter the redial list. Then scroll  to select a number in the list and press  **Select**. The number is dialed automatically.

4.1.4 Call from the call log

Note

- You need to subscribe to Caller Line Identification service to be able to see the caller's number or name in the call log. See section 5.9.1 - "Access the Call log".



- 1 Press  in idle mode, then scroll  to an entry in the call list.

Note



If the list is empty, then "List Empty" is displayed.

- 2 Press .
 - The call is initiated.







4.1.5 Call from the phonebook

- 1 Press  in idle mode.
- 2 Scroll  to a phonebook entry.
- 3 Press .
 - The call is initiated.

Tip



Instead of scrolling  to browse the phonebook entries, you can press the numeric key corresponding to the first letter of the entry you wish to locate. For example, pressing  will show the entries starting with A. Pressing  again will show the entries starting with B, etc.

4.1.6 Call from the phonebook while already on the phone

- 1 Press  **Option**.
- 2 Scroll  to **START 2ND CALL**, press  **Select**, press  **Option** then press  **Select**.
- 3 Scroll  to a phonebook entry.

- 4** Press  **Select**.
- The call is initiated.

4.1.7 Call using Direct Access Memory

Press a number key  to  for more than 2 seconds to dial a stored direct access memory number.

 **Note**

- See section 5.6.7 for instructions on how to store, edit, and delete direct access memory numbers.

4.1.8 Enter a Dialing Pause

Long press  to enter a pause in the dialling sequence. The pause is indicated by a P.

4.2 Answer a call

 **Danger**

When the handset rings during an incoming call, please do not hold the handset too close to your ear as the volume of the ringing tone may damage your hearing.

When the phone rings, press the  key.

- The call is established.

 **Note**

- Incoming call has priority over other events. Whenever there is an incoming call, other status in progress such as phone setting, menu navigation, etc will be aborted.

 **Tip**

You can mute the ring tone of an incoming call before answering by pressing on  **Silent**.

4.2.1 Handsfree answering

 **Danger**

Handsfree activation can suddenly increase the volume in the earpiece to a very high level. Make sure the handset is not too close to your ear.

When the phone rings, press .

- The handset loudspeaker is activated.

4.3 End a call

To end a conversation, press .

- The call ends.

 **Tip**

When auto hang-up is on, you can simply place the handset back to its base station or charger to end the call. This feature is activated by default.

 **Note**

The call duration (MM:SS) will be displayed on the handset screen for about 5 seconds.

5 Use more of your phone

5.1 Switch the handset off/on

To switch the handset off, press and hold  in idle mode for at least 5 seconds.





To switch it on, press and hold  for at least one second.

5.2 Keypad lock/unlock







Press and hold  for 3 seconds to lock/unlock the keypad in idle mode.





5.3 Text or number entry

When you select a field in which you can enter text, you can enter the letters that are printed on the keys by pressing the relevant key once or several times. For example, to enter the name “PAUL”:

- 1 Press  once: P
- 2 Press  once: PA
- 3 Press  twice: PAU
- 4 Press  three times: PAUL

The table below gives you the character assignment during text or number entry:



Keys	Assigned characters
	. 0, / : ; “ ’ ! ; ? ; * + - % \ ^ ~
	SPACE 1 @ _ # = < > () & € £ \$ ¥ [] { } ¢ § ...
	a b c 2 à æ ä å
	d e f 3 è é Δ Φ
	g h i 4 ì Î
	j k l 5 Λ

Keys	Assigned characters
	m n o 6 ñ õ ò
	p q r s 7 ß Π Θ Σ
	t u v 8 ù ü
	w x y z 9 ø Ω Ξ Ψ

The following additional characters are available depending on your country setting. (These characters cannot be used with SMS.)

â, á, ã, ç, ê, ë, ð, í, î, ï, ó, ô, õ, ø, ù, μ

* Tip

- Press  **Clear** to delete the last digit or character entered or long press to delete all.
- Short press  to shift between lowercase and uppercase.
- Long press  to insert a pause.

5.4 Call in progress



Some options are available to you during a call. The available options are :

5.4.1 Adjust earpiece or speaker volume

During a call, press  to select from **level 1** to **level 5**.

5.4.2 Mute/Unmute microphone



When the microphone is muted, your correspondent cannot hear you.

- 1 During a call, press  to turn off the microphone.
- 2 Press  again to turn on the microphone.

5.4.3 Activate/Deactivate loudspeaker mode







Danger

Handsfree activation can suddenly increase the volume in the earpiece to a very high level. Make sure the handset is not too close to your ear.

- 1 During a call, press  to activate the loudspeaker mode.
- 2 Press  again to deactivate the loudspeaker mode.

5.5 Chain dialing

This feature allows you to dial an extension to a number already saved in the phonebook during a call.

- 1 Press  or  on the handset to take the line. Then, press  **Option** and then  **Select** to enter the phonebook name list.
- 2 Scroll  to a phonebook entry.
- 3 Press  **Select**.
 - The first part is dialed.
- 4 Enter the extension.

5.6 Using your Phonebook





Your phone can store up to 200 phonebook memories. Each phonebook entry can have a maximum of 24 digits for the phone number and 14 characters for the name.

All names and numbers in the phonebook must be unique.



Note

If you have multiple handsets, the phonebook can only be accessed by one handset at a time.

5.6.1 Store a contact in the phonebook

- 1 Press  in idle mode. **Phonebook** is highlighted; press  **Select**.
- 2 **New Entry** is highlighted; press  **Select**.
- 3 **Enter Name** is displayed. Enter the name of the contact (maximum 14 characters) and press  **OK**.
- 4 **Enter Number** is displayed. Enter the number (maximum 24 digits) and press  **OK**.
 - A validation tone is emitted.





Note

- Press  **Clear** to delete the last digit or character entered or long press to delete all.
- To return to the previous menu, press  **Back**.



Tip



You cannot store a new phonebook entry when the memory is full. In this case, you have to delete existing entries to make space for new entries.

5.6.2 Access phonebook









- 1 Press  in idle mode and scroll  to browse the phonebook. (You can also access the phonebook through the menu mode.  → **Phonebook** → **List**)
 - The phonebook entries will be listed in alphabetical order.
- 2 To view the details, press  **View**.

* Tip

Instead of scrolling  to browse the phonebook entries, you can press the numeric key corresponding to the first letter of the entry you wish to locate. For example, pressing  will show the entries starting with A. Pressing  again will show the entries starting with B, etc.

- Press  to dial the number. (Press  to return to idle mode.)

5.6.3 Modify a phonebook entry

- Press  in idle mode. **Phonebook** is highlighted; press  **Select**.
- Scroll  to **Edit Entry** and press  **Select**.
- Scroll  to select an entry to edit.
- Press  **Select** to display the name.
- Press  **Clear** to erase the letters one by one.
- Edit the name and press  **OK** to confirm.
- Edit the number and press  **OK** to confirm.
 - A validation tone is emitted.

⊖ Note









While editing, press  **Clear** to delete the last digit or character entered or long press to delete all.

5.6.4 Select phonebook melody

With this function you can personalize the melody played when someone in the phonebook calls you.

⊖ Note







You need to subscribe to Caller Line Identification service to be able to benefit from this feature.

- Press  in idle mode. **Phonebook** is highlighted; press  **Select**.
- Scroll  to **Select Melody** and press  **Select**.
- Scroll  to the entry you want to select a melody for, then press  **View**.
- The screen shows the melody currently selected for that entry. Press  **Change** to change the melody.
- Scroll  the list of melodies. (There are 15 melodies plus **No Melody** to choose from. The melodies play as you scroll through them.)
- Press  **Select** to select the melody you prefer.
 - A validation tone is emitted and the screen returns to the **Phonebook** menu.

⊖ Note

When first ring detection is set **On**, a normal tone sounds first, and then it changes to the personalized phonebook melody. When it is set **Off**, the personalized phonebook melody plays from the start. See Section 7.10 for how to set first ring detection **On** or **Off**.





5.6.5 Delete a phonebook entry

- 1 Press  in idle mode.
Phonebook is highlighted; press  **Select**.
- 2 Scroll  to **Delete** and press  **Select**.
- 3 Scroll  to select an entry to delete and press  **Select**.
- 4 **Delete?** is displayed on the screen. Press  **OK** to confirm deletion.
 - A validation tone is emitted.



Note

Press  **Back** to discard the deletion. The screen returns to the phonebook list.

5.6.6 Delete all phonebook entries

- 1 Press  in idle mode.
Phonebook is highlighted; press  **Select**.
- 2 Scroll  to **Delete All** and press  **Select**.
- 3 **Delete All?** is displayed on the screen. Press  **OK** to confirm deletion.
 - A validation tone is emitted.

5.6.7 Direct access memories - PhoneMail











There are 7 direct access memories (Keys  to ) included in the phonebook memory. A long press on the keys in idle mode will automatically dial the stored phone number.

Note

The key  allows the use of **Phonemail** in services menu (Smart

phone services) offered by Belgacom. The Phonemail number (1230) is already set on .



5.6.7.1 Add/Edit Phonemail







- 1 Press  in idle mode.
Phonebook is highlighted; press  **Select**.
- 2 Scroll  to **Direct Memory** and press  **Select**.
 - The current number stored in the direct access memory location will be displayed. If no number is stored, **No number** will be displayed.
- 3 Scroll  to the key you wish to edit (**Key 3 to Key 9**) and press  **Menu**.
- 4 Scroll  to **Edit** and press  **Select**.
- 5 The Phonebook list will be displayed. Scroll  to the Phonebook entry you wish to store in the selected direct access memory number and press  **Select**.
- 6 Press  **OK** to confirm.
 - A validation tone is emitted and the screen returns to the previous menu.

Note

Each handset has its own direct access memories.

5.6.7.2 Delete Phonemail



- 1 Press  in idle mode.
Phonebook is highlighted; press  **Select**.

- 2 Scroll  to **Direct Memory** and press  **Select**.
- 3 Scroll  to the key you wish to delete the memory from and press  **Menu**.
- 4 Scroll  to **Delete** and press  **Select**.
 - A validation tone is emitted and the screen returns to the previous menu.

5.7 Using the Redial list

The redial list stores the last 10 numbers dialed. A maximum of 32 digits can be displayed for each entry.





5.7.1 Access Redial list

- 1 Press  to go to the redial list and scroll  to browse the redial list.
 - The last number dialed will appear first in the redial list. If the redial number matches a phonebook entry, the name will be displayed instead.
- 2 To open the redial list options, press  **Menu**.



Note

Press  **Back** to return to the previous menu.







5.7.2 View redial number details

- 1 Press  in idle mode, scroll  to select an entry and press  **Menu**.
- 2 **View** is highlighted on the screen; press  **Select** to display



information about the number dialed.

- 3 Press  **Next** to display further information. Afterward, you can press  **Prev.** to return to the former screen. After viewing, press  **Back** to return to previous menu levels.



5.7.3 Save a redial number into the phonebook

- 1 Press  in idle mode, scroll  to select an entry and press  **Menu**
- 2 **View** is highlighted on the screen. Scroll  to **Save Number** and press  **Select**.
- 3 **Enter Name** is displayed. Enter the name of the contact (maximum 14 characters) and press  **OK**.
- 4 **Enter Number** is displayed and the selected number from the redial list appears in the number field. At this time you can edit the number if you wish to.
- 5 Press  **OK**. The screen returns to the redial list.

Note

Press  **Clear** to delete the last digit or character entered. Long press  **Clear** to clear the entire entry.

5.7.4 Delete a redial number

- 1 Press  in idle mode, scroll  to select an entry and press  **Menu**.

2 Scroll  to **Delete** and press  **Select**.

3 **Delete?** is displayed on the screen.



4 Press  **OK** to confirm deletion.

- A validation tone is emitted.

Note

Press  **Back** to discard the deletion. The screen returns to the previous menu.

5.7.5 Delete all redial numbers

1 Press  in idle mode, and press  **Menu**.

2 Scroll  to **Delete All** and press  **Select**.



3 **Delete All?** is displayed on the screen.

4 Press  **OK** to confirm deletion.

- A validation tone is emitted.



5.8 Call waiting

If you have subscribed to Call Waiting services, the earpiece will emit a beep tone to inform you that there is a second incoming call. The number or name of the second caller will also be displayed if you have subscribed to Caller Line Identification service (CLI). Please contact Belgacom for more information on this service.

Press  and  to answer the call.

- The first call is put on hold, and you are now connected to the second call.

OR

Press  and  to end the current call and answer the second call.

5.9 Using the Call log



The call log stores the last 50 external calls and any new voice mail received. In idle mode, the  icon flashes on the display for new and unanswered calls. If you have subscribed to Caller Line Identification (CLI), and provided the identity of the caller is not withheld, the name (or number) of the caller will be displayed.

Note



If the identity of the caller is withheld or the network does not provide the date and time information, then the information will not be displayed in the call log.

If you have not subscribed to Caller Line Identification service, there will not be any caller information displayed in the call log.

5.9.1 Access the Call log







1 Press  in idle mode, and scroll  to browse the call log.

- The calls (missed and received) are displayed in chronological order with the most recent call at the top of the list. If the call is unviewed and unanswered, **New** appears on the display. After you view the message, **New** disappears.
- Press  to dial out the number of the selected call log entry.

2 To view the call details, press  **Menu** and then press  **Select**. The display shows the caller information.

- Press  **Back** at any time to return to the previous menu.







5.9.2 Save call list entry into the phonebook

- 1 Press  in idle mode, scroll  to select an entry and press  **Menu**.
- 2 Scroll  to **Save Number** and press  **Select**.
- 3 **Enter Name** is displayed on the screen. Enter the name of the contact (maximum 14 characters) and press  **OK**.
- 4 **Enter Number** is displayed and the selected number from the call list appears in the number field. At this time you can edit the number if you wish to.
- 5 Press  **OK**.
 - A confirmation tone sounds and the screen returns to call log.

Note

Press  **Clear** to delete the last digit or character entered or long press to delete all.

5.9.3 Delete a call list entry





- 1 Press  in idle mode, scroll  to select an entry and select  **Menu**.
- 2 Scroll  to **Delete** and press  **Select**.
- 3 **Delete?** is displayed on the screen.
- 4 Press  **OK** to confirm deletion.
 - A validation tone is emitted, the call list entry is deleted, and the

display goes to the next entry in the call list.

Note

Press  **Back** to discard the deletion. The screen returns to the **Call List** menu.

5.9.4 Delete all call list entries

- 1 Press  in idle mode, and then press  **Menu**.
- 2 Scroll  to **Delete All** and press  **Select**.
- 3 **Delete All?** is displayed on the screen. Press  **OK** to confirm deletion.
 - A validation tone is emitted. The display shows **List Empty** for 2 seconds and returns to the idle mode.

5.10 Using the Intercom

Warning

Intercom and call transfer is only possible when you have at least 2 handsets registered to the same base station. It allows you to make free internal calls, transfer external calls from one handset to another and use the conference option.



5.10.1 Intercom another handset

Note

If the handset does not belong to Twist619 range, this function may not be available.

- 1 Press  in idle mode.

- Intercom is established immediately if there are only 2 registered handsets.

2 If there are more than 2 registered handsets, scroll  to select the handset to call and press  **OK**.

- Once the intercom call is initiated the  icon is displayed on the handset.

3 Press  on the called handset.

- The intercom is established.



Note

Pressing  on any handset will exit intercom mode and return other handsets to idle mode. If an external call arrives during intercom mode and you want to accept this call, you must first exit intercom mode.

5.10.2 Transfer an external call to another handset

1 During the call, press  to put the external call on hold (the caller can no longer hear you).

- The display shows the numbers of the handsets registered to the base.

2 Scroll  to the handset number you wish to transfer your external call to and press  **Select**.

3 Press  on the called handset to answer the internal call, where both internal callers can talk.

- Intercom is established.

4 Press  on the first handset to transfer the external call to the called handset.

- The external call is transferred.

Note

If there is no answer from the called handset, press  to resume the external call.

5.10.3 Answer an external call during intercom

1 During intercom, a new call tone is emitted when there is an incoming external call.

2 Press  to exit intercom mode.

3 Press  to pick up the external call.

5.10.4 Switch between an internal and external call

During the call, press  to switch between an internal or external call.

5.10.5 Establish a three-party conference call



The conference call feature allows one external call to be shared with two handsets (in intercom). The three parties can share the conversation and no network subscription is required.

1 During the call, press  to put the external call on hold (the caller can no longer hear you).

- The display shows the numbers of the handsets registered to the base.



2 Scroll  to the number of the handset you wish to establish the

conference call with and press 
Select.

- 3 Press  on the called handset to answer the internal call, where both internal callers can talk.
 - Intercom is established.
- 4 Press  **Conf.** or long press  on the first handset to start the three-party conference.
 - **Conference** will be displayed on the screen once the conference call is established.

5.11 Paging

The paging feature enables you to locate a missing handset if the handset is in range and contains charged batteries.

- 1 Press  on the base station.
 - All the registered handsets start to ring.
 - Once a handset is found, press  **Silent** on a handset to stop its ringing.
- 2 Press  again to end the paging.









Note

If there are no key presses within 30 seconds, the handset will automatically return to idle mode.

5.12 Clock and Alarm settings

This feature allows you to set the date, time and alarm settings for your phone.

5.12.1 Set Date and Time

- 1 Press  in idle mode, scroll  to **Clock & Alarm**, and press 
Select.
- 2 **Set Date/Time** is highlighted. Press 
Select.
- 3 The last stored date and time are displayed. Enter the current time and current date (HH:MM DD/MM/YY). Press  to move the cursor left, or press  to move it right. If using the 12 hour format, just after setting the minutes, use  to switch between AM and PM.
- 4 Press 
OK.
 - A validation tone is emitted and the screen returns to the idle mode.











Note

The date format and time format are initially determined by the country selection. However, you can change the format as shown in the next section.









5.12.2 Set Time and Date Format

5.12.2.1 Set Time Format









- 1 Press  in idle mode, scroll  to **Clock & Alarm**, and press 
Select.
- 2 Scroll  to **Set Format** and press 
Select.
- 3 **Time Format** is highlighted in the display. Press  **Select**, then scroll  to select **12hours** or **24hours**.

- 4 Press  **Select** to select the option.
 - A validation tone is emitted and the screen returns to the **Set Format** menu.

5.12.2.2 Set Date Format

- 1 Press  in idle mode, scroll  to **Clock & Alarm**, and press  **Select**.
- 2 Scroll  to **Set Format** and press  **Select**.
- 3 Scroll  to **Date Format** and press  **Select**.
- 4 Scroll  to select **DD/MM** or **MM/DD** and press  **Select** to select the option.
 - A validation tone is emitted and the screen returns to the **Set Format** menu.

5.12.3 Set Alarm

- 1 Press  in idle mode, scroll  to **Clock & Alarm**, and press  **Select**.
- 2 Scroll  to **Alarm** and press  **Select**.
- 3 Scroll  to **Off**, **On Once**, or **On Daily** and press  **Select**.
- 4 If you select **On Once** or **On Daily**, enter the time (HH-MM) for the alarm. (If using the 12 hour format, you can switch between AM and PM by pressing .) Press  **OK** to confirm.
 - A validation tone is emitted and the screen returns to the **Alarm**







menu. And the alarm icon  is displayed.

- If you select **Off**, a validation tone is emitted and the screen returns to the **Clock & Alarm** menu.

Note

The alarm tone and alarm icon will sound/blink for 1 minute when the alarm time is reached. To mute the alarm tone, simply press any key on the handset.







5.12.4 Set Alarm Tone

- 1 Press  in idle mode, scroll  to **Clock & Alarm**, and press  **Select**.
- 2 Scroll  to **Alarm Tone** and press  **Select**.
- 3 Scroll  to select the tone. (Three tones are available. The tones sound as you scroll.) Press  **Select** to confirm your selection.
 - A validation tone is emitted and the screen returns to the **Clock & Alarm** menu.

6 Personal settings

6.1 Change the Handset Name

You can name the handset and display the handset name in idle mode. The default handset name of your handset is Belgacom.

- 1 Press  in idle mode, scroll  to **Personal Set** and press  **Select**.
- 2 **Handset Name** is highlighted; press  **Select**.
- 3 The last stored name is displayed. Press  **Clear** to delete the characters one by one or a long press to delete all.
- 4 Enter the new name and press  **OK** to confirm.
 - A validation tone is emitted and the screen returns to the **Personal Set** menu.

6.2 Handset Tones









6.2.1 Set the Ring Volume

Danger

When the handset rings during an incoming call, please do not hold the handset too close to your ear as the volume of the ringing tone may damage your hearing.

In multihandset packs, you can set the ring volume independently on each

registered handset. There are 5 ringer volume levels plus progressive and off. The default is level 3.

- 1 Press  in idle mode, scroll  to **Personal Set**, and press  **Select**.
- 2 Scroll  to **Handset Tones** and press  **Select**. **Ring Volume** is highlighted; press  **Select**.
- 3 Scroll  to your desired volume level. The ring tone sounds at each level.
- 4 Press  **OK** to confirm.
 - A validation tone is emitted and the screen returns to the **Handset Tones** menu.









Note

If ring volume is set to off, the  icon will be displayed on the screen.

If ring volume is set to progressive, the ringer will start at level 1 and go up one level volume every ring.

6.2.2 Set the Ring Tones









There are 15 ring tones available on your handset.

- 1 Press  in idle mode, scroll  to **Personal Set**, and press  **Select**.
- 2 Scroll  to **Handset Tones** and press  **Select**. Then scroll  to **Ring Tones** and press  **Select**.
- 3 Scroll  to your desired melody. The melodies will play as you scroll them.
- 4 Press  **Select** to set the ring tone.

- A validation tone is emitted and the screen returns to the **Handset Tones** menu.







6.2.3 Activate/Deactivate Key Beep

A single beep tone is emitted when a key is pressed. You can enable or disable the key beep.

- 1 Press  in idle mode, scroll  to **Personal Set**, and press  **Select**.
- 2 Scroll  to **Handset Tones** and press  **Select**. Then scroll  to **Key Beep** and press  **Select**.
- 3 Scroll  to select **On** or **Off** and press  **Select** to confirm.
 - A validation tone is emitted and the screen returns to the **Handset Tones** menu.

6.3 Change the Display Language

Your handset can support different display languages.

- 1 Press  in idle mode, scroll  to **Personal Set**, and press  **Select**.
- 2 Scroll  to **Language** and press  **Select**.
- 3 Scroll  to your desired language and press  **Select** to confirm.
 - A validation tone is emitted and the screen returns to the **Personal Set** menu.







Note

Once the display language is set, the option menus on the handset will

immediately switch to display in the selected language.







6.4 Select the Display Wallpaper

There are 3 wallpaper images available on your handset as well as an option to set it off.

- 1 Press  in idle mode, scroll  to **Personal Set**, and press  **Select**.
- 2 Scroll  to **Wallpaper** and press  **Select**.
- 3 Scroll  to your desired wallpaper. The image on the display will change as you scroll.
- 4 Press  **Select** to confirm.
 - A validation tone is emitted and the screen returns to the **Personal Set** menu.







6.5 Select the Color Theme

There are 4 color themes available on your handset.

- 1 Press  in idle mode, scroll  to **Personal Set**, and press  **Select**.
- 2 Scroll  to **Color Theme** and press  **Select**.
- 3 Scroll  to your desired color theme. The color theme used on the display will change as you scroll.
- 4 Press  **Select** to confirm.
 - A validation tone is emitted and the screen returns to the **Personal Set** menu.







6.6 Set the Display Contrast

You can change the contrast of the text on the display. There are 5 contrast levels available on your handset. The default is level 3.

- 1 Press  in idle mode, scroll  to **Personal Set**, and press  **Select**.
- 2 Scroll  to **Contrast** and press  **Select**.
- 3 Scroll  to the desired display contrast, and press  **Select** to confirm.
 - A validation tone is emitted and the screen returns to the **Personal Set** menu.

6.7 Set the Backlight Time

You can change the backlight timing for the display. There are 3 options available - 20, 40, or 60 seconds.







- 1 Press  in idle mode, scroll  to **Personal Set**, and press  **Select**.
- 2 Scroll  to **Backlight Time** and press  **Select**.
- 3 Scroll  to the desired backlight time, and press  **Select** to confirm.
 - A validation tone is emitted and the screen returns to the **Personal Set** menu.

6.8 Deactivate/Activate Auto Hang-Up

If auto hang-up is set to On, it will automatically release the line when the phone is put back on the cradle.

If auto Hang-up is set to Off, putting the handset back on the cradle while in talk mode will switch the handset to hands free talk mode. This allows you to charge the handset during calls.

The default setting for auto hang up is On.

- 1 Press  in idle mode, scroll  to **Personal Set**, and press  **Select**.
- 2 Scroll  to **Auto Hang-up** and press  **Select**.
- 3 Scroll  to **On** or **Off** and press  **Select** to confirm.
 - A validation tone is emitted and the screen returns to the **Personal Set** menu.











7 Advanced settings

7.1 Easy Call

When activated, this feature allows you to dial a preset number by pressing any key on the handset (except  **Cancel**). This feature is useful for fast access to emergency services.





7.1.1 Set Easy Call to On or Off

Follow this procedure to switch Easy Call on. To switch Easy Call off, see the Note at the end of this section.







- 1 Press  in idle mode, scroll  to **Advanced Set** and press  **Select**.
- 2 **Easy Call** is highlighted. Press  **Select** to enter the Easy Call menu.
- 3 **Mode** is highlighted in the display. Press  **Select** again to select **Mode**, then scroll  to **On**.
- 4 Press  **Select** to confirm the selection.
 - If an Easy Call number has not been set, you will be prompted to input the Easy Call number.
 - If an Easy call number has already been set, the screen returns to idle mode. If you want to edit the number, press  **Cancel** and scroll to **Number** and press  **Select**, edit the new number and press  **OK**.

Note

When you switch Easy Call on, **Easy Call On** will be displayed on your screen in standby mode. You can still answer any incoming call as normal.







To switch Easy Call off from idle mode, press  **Cancel**. **Mode** is highlighted in the display. Press  **Select** again to select **Mode**, and then scroll  to **Off**. Press  **Select** to confirm.

7.1.2 Set Easy Call number

- 1 Press  in idle mode, scroll  to **Advanced Set** and press  **Select**.
- 2 **Easy Call** is highlighted in the display. Press  **Select** to enter the Easy Call menu.
- 3 **Mode** is highlighted in the display. Scroll  to **Number** and press  **Select**.
- 4 Input the Easy Call number.
- 5 Press  **OK** to confirm.
 - A validation tone is emitted and the screen returns to the **Easy Call** menu.

7.2 Auto Conference

If activated, this feature allows another handset to join a conversation with an external call by simply pressing . The default setting is **Off**.

- 1 Press  in idle mode, scroll  to **Advanced Set** and press  **Select**.
- 2 Scroll  to **Conference** and press  **Select**.
- 3 Scroll  to select **On** or **Off** and press  **Select** to confirm.
 - A validation tone is emitted and the screen returns to the **Advanced Set** menu.

7.3 Call Barring

If activated, this function prevents dialing out to numbers beginning with designated barring numbers. This is useful for preventing outgoing long









distance calls or calls to specific prefixes. You can store up to four numbers, each with up to 4 digits.

Note





If you switch call barring on, **Call Barr On** is displayed on the screen in idle mode. By default call barring is off.

7.3.1 Set Call Barring Mode











By default, Call Barring is **OFF**.

- 1 Press  in idle mode, scroll  to **Advanced Set** and press  **Select**.
- 2 Scroll  to **Call Barring** and press  **Select**.
- 3 Enter the PIN number.
 - If you enter an incorrect PIN number, an error tone will sound and “Wrong PIN!” will be displayed. Then, the display will return to idle screen.
- 4 **Mode** is highlighted in the display. Press  **Select**.
- 5 Scroll  to select **On** or **Off** and press  **Select** to confirm.
 - If a Call Barring number has not been set, you will be prompted to input a Call Barring number.

Note

To switch Call Barring mode off again from idle mode, press  **Cancel** and enter the PIN number. **Mode** is highlighted in the display. Press  **Select** to select **Mode**, then scroll  to **Off** and press  **Select**.







7.3.2 Set a Call Barring number

- 1 Press  in idle mode, scroll  to **Advanced Set** and press  **Select**.
- 2 Scroll  to **Call Barring** and press  **Select**.
- 3 Enter the PIN number.
- 4 **Mode** is highlighted in the display. Scroll  to **Number** and press  **Select**.
- 5 Scroll  to select a call barring number location, and press  **Select** to confirm.
- 6 Input the call barring number (up to 4 digits) and press  **OK**.
 - A validation tone is emitted and the screen returns to the **Call Barring** menu.

7.4 XHD Sound

XHD (extra high definition) Sound can increase voice quality when **On**. The default setting is **On**.

To turn it off:









- 1 Press  in idle mode, scroll  to **Advanced Set** and press  **Select**.
- 2 Scroll  to **XHD Sound** and press  **Select**.
- 3 Scroll  to select **On** or **Off** and press  **Select** to confirm.
 - A validation tone is emitted and the screen returns to the **Advanced Set** menu.

7.5 Change PIN

The PIN is used for setting call barring numbers and registration/unregistration of handsets. The default PIN number is 0000. This PIN is also used to protect the settings of your handset. Your handset will prompt you whenever the PIN is required.

Note

The default PIN code is preset to 0000. If you change this PIN code, keep the PIN details in a safe place where you have easy access to them. Do not lose the PIN code.

- 1 Press  in idle mode, scroll  to **Advanced Set** and press  **Select**.
- 2 Scroll  to **Change PIN** and press  **Select**.
- 3 **Old PIN:** will be displayed. Enter the current PIN and press  **OK**.
 - The PIN entered will be shown as asterisks (*) on the screen.
 - If you enter an incorrect PIN number, an error tone will sound and “Wrong PIN!” will be displayed. Then, you will be prompted to enter the current PIN again.
- 4 **New PIN:** will be displayed. Enter the new PIN and press  **OK**.
- 5 **Confirm PIN:** will be displayed. Enter the new PIN again and press  **OK** to confirm PIN change.
 - A validation tone is emitted, **Saved!** is displayed and the screen returns to the **Advanced Set** menu.

Tip







If you forget your PIN, you will need to reset your phone to its default settings. For more details, see section 7.8 - “Reset Unit.”

7.6 Registration

If you wish to register an additional handset or if you have inadvertently unregistered your phone's handset and want to re-register it, follow the procedure described below. This is the procedure for registering Twist619 handsets. Procedures may vary for other types of handsets. In this case, please refer to the manufacturer of the handset. Additional handsets must be registered to the base station before you can use them. Up to 5 handsets can be registered to one base station. The PIN is required before you can register or unregister handsets.

Note

By default, the PIN is 0000.

- 1 On the base station, press and hold  for 3 seconds. A beep sounds to indicate that the base is ready to accept registration.
-  **Note**
If no action is taken on the handset within 90 seconds, the registration procedure will be aborted. If this happens, repeat from Step 1.
- 2 On the handset, press , scroll  to **Advanced Set** and press  **Select**.
- 3 Scroll  to **Register** and press  **Select**.

- 4 Enter the PIN when prompted and press  **OK** to confirm. **Registering...** is displayed on the screen.
- Upon successful registration, a validation tone is emitted and the handset number (1 to 5) will be assigned by the base automatically.







7.6.1 Easy registration



- 1 Insert the unregistered handset in the base station to automatically begin registration.
- 2 **Registering...** is displayed on the screen.
- Upon successful registration, a validation tone is emitted and the handset number (1 to 5) will be assigned by the base automatically.

Note

The easy registration is possible only when PIN has not been changed and is still the default PIN 0000.

7.7 Unregister

- 1 Press  in idle mode, scroll  to **Advanced Set** and press  **Select**.
- 2 Scroll  to **Unregister** and press  **Select**.
- 3 Enter the PIN when prompted and press  **OK** to confirm.

- 4 Scroll  to select the handset number to unregister and press  **Select**. Press  **OK** to confirm.
- A validation tone is emitted to indicate successful unregistration.

Note

You can only use a Twist619 handset to unregister a handset that does not belong to the Twist619 range.

7.8 Reset Unit







You can reset your phone to its default settings with this feature. (see 7.11 “Default Settings”)

Warning

Upon reset, all your personal settings, call log and redial list entries will be deleted and the phone will return to its default settings. However, your phonebook will remain unchanged after reset.

Note







You may have to configure your phone once again.

- 1 Press  in idle mode, scroll  to **Advanced Set** and press  **Select**.
- 2 Scroll  to **Reset** and press  **Select**.
- 3 **Reset?** is displayed on the screen. Press  **OK** to confirm.
- A validation tone is emitted.
 - The unit is reset to its default settings. (See section 7.11 below.)

7.9 Change Flash time

Flash time is the time delay by which the line will be disconnected after you press the  key. It can be set to short or long.

The default value of recall time that is preset in your handset should be the best suited for Belgacom and therefore you should not need to change it.







- 1 Press  in idle mode, scroll  to **Advanced Set**, and press  **Select**.
- 2 Scroll  to **Recall Time**, and press  **Select**.
- 3 Scroll  to **Short** or **Long** and press  **Select** to confirm.
 - A validation tone is emitted and the screen returns to the **Advanced Set** menu.

Note

The use of your Twist619 cannot be guaranteed on all PABX.

7.10 Set First Ring Detection

First ring detection allows the phone to ring upon reception of the first ring signal. It is recommended that you set first ring detection **Off** if you subscribe to caller line identification service. (When using personalized phonebook melodies, this will prevent a normal ring tone from sounding before a melody starts playing.) If you do not subscribe to caller line identification service, it is recommended that you set first ring detection **On**. (See Section 5.6.4.)

- 1 Press  in idle mode, scroll  to **Advanced Set**, and press  **Select**.
- 2 Scroll  to **First Ring** and press  **Select**.
- 3 Scroll  to **On** or **Off** and press  **Select** to confirm.
 - A validation tone is emitted and the screen returns to the **Advanced Set** menu.

Note

The default setting for first ring detection is country dependent. In countries where the default setting is **On**, the setting automatically switches to **Off** when you receive a call containing caller line identification. However, this occurs only if you do not first manually change the setting. (It does not change automatically if you manually change the first ring setting even once.)

7.11 Default Settings

Parameter	Default Value
Ring Volume	Level 3
Ring Tone	Ring 1
Earpiece Volume	Level 3
Speaker Volume	Level 3
Key Beep	On
Wallpaper	Wallpaper 1
Color Theme	Color 1
Display Contrast	Level 3
Backlight Time	20 Seconds

Parameter	Default Value
Auto Hang-Up	On
Handset Name	Belgacom
Time/Date	00:00 01/01/2008
Set Alarm	Off
Alarm Tone	Bell 2
PIN Code	0000
Call Barring	Off
Call Barring Number	Cleared
Xhd Sound	On
Easy Call	Off
Easy Call Number	Cleared
Phonebook Memory	After a reset, phonebook is maintained as it was just before the reset
Redial Memory	Cleared
CLI Memory	Cleared
Auto Conference	Off

8 Network Services

The network service functions provide a convenient way for you to access some network provider services. Subscriptions are required in order to benefit from these services. Contact Belgacom for details.



Note

The **Call Forward**, **Call Forward when Busy**, and **Call Forward when Unanswered** functions require activation codes (prefix and suffix) and a deactivation code. You must get these codes from your service provider.













8.1 Call Forward

You can use **Call Forward** to forward incoming calls to another number. This can be useful if you want calls to go to another number overnight or when traveling. You can activate or deactivate Call Forward as follows:



- 1 Press in idle mode, scroll to **Netw. Services**, and press **Select**.
- 2 Scroll to **Call Forward** and press **Select**.
- 3 To activate **Call Forward**, scroll to **Activate** and press **Select**. To deactivate **Call Forward**, scroll to **Deactivate** and press **Select**.
- 4 If you selected **Activate**, you will be prompted to enter the number for call forward. Enter the number (maximum 24 digits) and press **OK**.
- 5 The Call forward codes and the number are dialed. Press and return to idle mode.

8.1.1 Change Call Forward Activation Codes

There are two parts to the Call Forward activation code - a prefix and a suffix.

- 1 Press  in idle mode, scroll  to **Netw. Services**, and press  **Select**.
- 2 Scroll  to **Call Forward** and press  **Select**.
- 3 Scroll  to **Change Code** and press  **Select**.
- 4 Scroll  to **Activation** and press  **Select**.
- 5 You are now at the **Activation** screen. Scroll  to **Prefix** or **Suffix**, then press  **Select**.
- 6 You will be prompted to enter the prefix/suffix code. Enter the number (maximum 14 digits) and press  **OK**.
 - A confirmation tone will sound and the display will return to the **Activation** screen.



Note







Press  **Clear** to delete entered numbers. Long press  **Clear** to clear the entire entry.

- 7 Repeat from step 5 until you are finished inputting both the prefix and suffix codes.



8.1.2 Change Call Forward Deactivation Code

You must get the deactivation code from your service provider.

- 1 Press  in idle mode, scroll  to **Netw. Services**, and press  **Select**.









- 2 Scroll  to **Call Forward** and press  **Select**.
- 3 Scroll  to **Change Code** and press  **Select**.
- 4 Scroll  to **Deactivation** and press  **Select**.
- 5 Enter the deactivation code (maximum 14 digits) and press  **OK**.
 - A confirmation tone will sound and the display will return to the **Call Forward** screen.

Note

Press  **Clear** to delete entered numbers. Long press  **Clear** to clear the entire entry.

8.2 Call Forward when Busy













This function will forward incoming calls to another number if the line is busy. You can activate or deactivate Call Forward when Busy as follows:

- 1 Press  in idle mode, scroll  to **Netw. Services**, and press  **Select**.
- 2 Scroll  to **Call Fwd Busy** and press  **Select**.
- 3 To activate **Call Fwd Busy**, scroll  to **Activate** and press  **Select**. To deactivate **Call Fwd Busy**, scroll to **Deactivate** and press  **Select**.
- 4 If you selected **Activate**, you will be prompted to enter the number for call forward when busy. Enter the number (maximum 24 digits) and press  **OK**.



- 5 The Call forward when busy codes and the number are dialed. Press  and return to idle mode.

8.2.1 Change Call Forward when Busy Activation Codes

There are two parts to the Call Forward when Busy activation code - a prefix and a suffix.











- 1 Press  in idle mode, scroll  to **Netw. Services**, and press  **Select**.
- 2 Scroll  to **Call Fwd Busy** and press  **Select**.
- 3 Scroll  to **Change Code** and press  **Select**.
- 4 Scroll  to **Activation** and press  **Select**.
- 5 You are now at the **Activation** screen. Scroll  to **Prefix** or **Suffix**, then press  **Select**.
- 6 You will be prompted to enter the prefix/suffix code. Enter the number (maximum 14 digits) and press  **OK**.
 - A confirmation tone will sound and the display will return to the **Activation** screen.

Note



Press  **Clear** to delete entered numbers. Long press  **Clear** to clear the entire entry.

- 7 Repeat from step 5 until you are finished inputting both the prefix and suffix codes.

8.2.2 Change Call Forward when Busy Deactivation Code









- 1 Press  in idle mode, scroll  to **Netw. Services**, and press  **Select**.
- 2 Scroll  to **Call Fwd Busy** and press  **Select**.
- 3 Scroll  to **Change Code** and press  **Select**.
- 4 Scroll  to **Deactivation** and press  **Select**.
- 5 Enter the deactivation code (maximum 14 digits) and press  **OK**.
 - A confirmation tone will sound and the display will return to the **Call Fwd Busy** screen.

Note

Press  **Clear** to delete entered numbers. Long press  **Clear** to clear the entire entry.

8.3 Call Forward when Unanswered

This function will forward unanswered calls to another number. You can activate or deactivate Call Forward when Unanswered as follows:

- 1 Press  in idle mode, scroll  to **Netw. Services**, and press  **Select**.
- 2 Scroll  to **Call Fwd Unans** and press  **Select**.
- 3 To activate **Call Fwd Unans**, scroll  to **Activate** and press  **Select**. To deactivate **Call Fwd Unans**, scroll to **Deactivate** and press  **Select**.

- If you selected **Activate**, you will be prompted to enter the number for call forward when unanswered. Enter the number (maximum 24 digits) and press **OK**.
- The Call forward when unanswered codes and the number are dialed. Press and return to idle mode.

8.3.1 Change Call Forward when Unanswered Activation Codes

There are two parts to the Call Forward when Unanswered activation code - a prefix and a suffix.

- Press in idle mode, scroll to **Netw. Services**, and press **Select**.
- Scroll to **Call Fwd Unans** and press **Select**.
- Scroll to **Change Code** and press **Select**.
- Scroll to **Activation** and press **Select**.
- You are now at the **Activation** screen. Scroll to **Prefix** or **Suffix**, then press **Select**.
- You will be prompted to enter the prefix/suffix code. Enter the number (maximum 14 digits) and press **OK**.
 - A confirmation tone will sound and the display will return to the **Activation** screen.

Note

Press **Clear** to delete entered numbers. Long press **Clear** to clear the entire entry.

- Repeat from step 5 until you are finished inputting both the prefix and suffix codes.

8.3.2 Change Call Forward when Unanswered Deactivation Code

- Press in idle mode, scroll to **Netw. Services**, and press **Select**.
- Scroll to **Call Fwd Unans** and press **Select**.
- Scroll to **Change Code** and press **Select**.
- Scroll to **Deactivation** and press **Select**.
- Enter the deactivation code (maximum 14 digits) and press **OK**.
 - A confirmation tone will sound and the display will return to the **Call Fwd Unans** screen.

Note



Press **Clear** to delete entered numbers. Long press **Clear** to clear the entire entry.

8.4 Phonemail









Use this function to access your Phonemail account.

8.4.1 Access Phonemail

- Press in idle mode, scroll to **Netw. Services**, and press **Select**.

- 2 Scroll  to **Voicemail** and press  **Select**.
- 3 You are now at the **Voicemail** menu and **Call** is highlighted. Press  **Select** to connect to the voice mail account number.





8.4.2 Set Phonemail Number

- 1 Press  in idle mode, scroll  to **Netw. Services**, and press  **Select**.
- 2 Scroll  to **Voicemail** and press  **Select**.
- 3 Scroll  to **Settings** and press  **Select**.
- 4 Enter the voice mail account number (maximum 14 digits) and press  **OK**.
 - A confirmation tone will sound and the display will return to the **Voicemail** screen.

8.5 Call Return









This function allows you to get information on who called you last.

8.5.1 Access the Call Return Service

- 1 Press  in idle mode, scroll  to **Netw. Services**, and press  **Select**.
- 2 Scroll  to **Call Return** and press  **Select**.
- 3 You are now at the **Call Return** menu and **Call** is highlighted. Press

 **Select** to connect to the pre-programmed number (1919).







8.5.2 Set Call Return Service Number

- 1 Press  in idle mode, scroll  to **Netw. Services**, and press  **Select**.
- 2 Scroll  to **Call Return** and press  **Select**.
- 3 Scroll  to **Settings** and press  **Select**.
- 4 Enter the call return service number (maximum 14 digits) and press  **OK**.
 - A confirmation tone will sound and the display will return to the **Call Return** screen.

8.6 Cancel Call Back









When calling a busy line, some operators prompt you to press a key to activate a call back option. By activating the call back option, you will receive a call from the network as soon as your correspondent's line is free. When responding to this call, the network will automatically connect you to that correspondent. Your answering machine will not answer to this call and your call log will not record this call either. The Cancel call back feature enables you to deactivate the call back feature when you have activated it.

8.6.1 Call the Cancel Call Back Number

- 1 Press  in idle mode, scroll  to **Netw. Services**, and press  **Select**.
- 2 Scroll  to **Cancel Call BK** and press  **Select**.
- 3 You are now at the **Cancel Call BK** menu and **Call** is highlighted. Press  **Select** to connect to the Cancel Call Back number.

8.6.2 Set the Cancel Call Back Number

Get the cancel call back number from your service provider.

- 1 Press  in idle mode, scroll  to **Netw. Services**, and press  **Select**.
- 2 Scroll  to **Cancel Call BK** and press  **Select**.
- 3 Scroll  to **Settings** and press  **Select**.
- 4 Enter the cancel call back number (maximum 14 digits) and press  **OK**.
 - A confirmation tone will sound and the display will return to the **Cancel Call BK** screen.

9 Short Message Service (SMS)





SMS stands for Short Message Service. To benefit from this service, you must subscribe to Caller Line Identification Service (CLI) together with SMS service from your network provider. SMS messages can be exchanged with a phone (mobile or compatible fixed lines), provided the receiver has also subscribed to CLI and SMS services. The factory settings on your handset correspond to the main national operator. If you wish to send or receive SMS messages through another service provider, you must set the corresponding numbers (see section 9.4.2).

Your handset can store up to 50 SMS messages and the maximum length of each message is 160 characters.

Note

See 5.3 text or number entry for characters usable with Short Message Service.



9.1 Write and Send an SMS

- 1 Press  in idle mode, scroll  to **SMS**, and press  **Select**.
- 2 **Write SMS** will be selected in the display. Press  **Select**.
- 3 The **Write SMS** screen will display. Enter your message (maximum 160 characters) and press  **OK**.



4 The display will show **Send to:**, prompting you to enter the number that you want to send the message to.

5 You can input the number directly.



Or

Press  **Menu** and then 

Select to open the phonebook.

Scroll  to the phonebook contact you want and press  **Select**.

 **Note**



Press  **Clear** to delete entered numbers. Long press  **Clear** to clear the entire entry and go to the phonebook to select another number.

6 Press  **OK**.

- At this point you may be requested to enter a box number. (This is country dependent) If so, enter the box number and press  **OK**. (See the note below).

7 At this point you have the options to send the message or save it as a draft.

To send the message: Press  **Select**.

To save a draft: Scroll down  to **Save as Draft** and press  **Select**.

- If the message is successfully sent, **“SMS Sent!”** will display and then the handset will return to the idle mode.
- If the message is not sent, **“SMS not Sent!”** will display. The message will be saved as a draft

and then the handset will return to the idle mode.

 **Note**



The purpose of the destination box number is to make sure that the SMS will be well received on the destination phone.



The default box number is programmable and you can change it in the SMS settings menu under “SMS” → “Settings” → “SMS Reception” → “Change Box Nr”.

9.2 Inbox



The Inbox is where you read your SMS messages. A submenu allows you to **Reply** messages, **Forward** messages, **Save Numbers** of messages, **Delete** messages, and **Delete all** messages.

9.2.1 Read SMS Messages (Check Inbox)

1 Press  in idle mode, scroll  to **SMS**, and press  **Select**.

2 Scroll  to **Inbox** and press  **Select** to open the SMS inbox.



3 Scroll  to scroll through the messages.

- If a message is from the number of someone in your phonebook, the phonebook information will be displayed.
- 4 Press  **View** to open an SMS message.
 - When you have finished reading a message, press  **Back** to return to the SMS inbox.





Note

If the inbox is empty, “**No Message**” will display for 2 seconds and the handset will return to idle mode.

9.2.2 Reply to an SMS Message





- 1 Open an SMS message. (See 9.2.1 above.)
- 2 Press  **Option** to open the inbox submenu. **Reply** is highlighted; press  **Select**.
- 3 The **Write SMS** screen will display. Enter your message.
The procedure then is similar to the normal procedure for writing an SMS message. (See 9.1 above.)

9.2.3 Forward an SMS Message





- 1 Open an SMS message. (See 9.2.1 above.)
- 2 Press  **Option** to open the inbox submenu, then scroll  to **Forward** and press  **Select**.
- 3 The **Write SMS** screen will display with the message you are forwarding already input. You can modify the message at this time.
- 4 When you are finished editing the message press  **OK**.
- 5 The display will show **Send to:**, prompting you to enter the number that you want to send the message to.
The procedure then is similar to the normal procedure for writing an SMS message. (See 9.1 above.)

9.2.4 Save the Number of an SMS Message





This saves the SMS sender's number in your phonebook.

- 1 Open an SMS message. (See 9.2.1 above.)
- 2 Press  **Option** to open the inbox submenu, then scroll  to **Save Number** and press  **Select**.
- 3 **Enter Name** is displayed. Enter the name of the contact (maximum 14 characters) and press  **OK**.
- 4 **Enter Number** is displayed. The number of the message you received is already input. You can edit it before saving. Press  **OK** when you are finished.
 - **Saved!** is displayed for 2 seconds and the display returns to the SMS inbox.

9.2.5 Delete an SMS Message

- 1 Open an SMS message. (See 9.2.1 above.)
- 2 Press  **Option** to open the inbox submenu, then scroll  to **Delete** and press  **Select**.
- 3 **Delete?** is displayed. Press  **OK** to delete the message. (Press  **Back** to return to the SMS submenu.)
 - **Deleted!** is displayed for 2 seconds and the display returns to the SMS inbox.









9.2.6 Delete all SMS Messages

- 1 Open an SMS message. (See 9.2.1 above.)
- 2 Press  **Option** to open the inbox submenu, then scroll  to **Delete All** and press  **Select**.
- 3 **Delete All?** is displayed. Press  **OK** to delete all your SMS messages. (Press  **Back** to return to the SMS submenu.)
 - **Waiting...** is displayed for a moment then **Deleted!** is displayed briefly, and the display returns to the **SMS** menu.

9.3 Drafts

The drafts box is where you can keep SMS messages.



9.3.1 Open a Draft

- 1 Press  in idle mode, scroll  to **SMS**, and press  **Select**.
- 2 Scroll  to **Drafts** and press  **Select** to open the drafts box.
- 3 Scroll  through the draft messages.
 - If a message is from the number of someone in your phonebook, the phonebook information will be displayed.
- 4 Press  **View** to open an SMS message.
 - When you have finished, press  **Back** to return to the drafts box.

Note





If the drafts box is empty, “**No Message**” will display for 2 seconds and the handset will return to idle mode.

9.3.2 Send a Draft

- 1 Open a draft message. (See 9.3.1 above.)
- 2 Press  **Option** to open the drafts submenu. **Send** is highlighted; press  **Select**.
- 3 The display will show **Send to;** prompting you to enter the number that you want to send the message to.





The procedure then is similar to the normal procedure for sending an SMS message. (See 9.1 above.)

9.3.3 Edit a Draft





- 1 Open a draft message. (See 9.3.1 above.)
- 2 Press  **Option** to open the drafts submenu, then scroll  to **Edit** and press  **Select**.
- 3 The **Write SMS** screen will display with the draft message ready to edit.
- 4 When you are finished editing the message press  **OK**.

The procedure then is similar to the normal procedure for sending an SMS message. (See 9.1 above.)

9.3.4 Delete a Draft

- 1 Open a draft message. (See 9.3.1 above.)
- 2 Press  **Option** to open the drafts submenu, then scroll  to **Delete** and press  **Select**.
- 3 **Delete?** is displayed. Press  **OK** to delete the message. (Press  **Back** to return to the drafts submenu.)
 - **Deleted!** is displayed for 2 seconds and the display returns to the SMS inbox.

9.3.5 Delete all Drafts









- 1 Open a draft message. (See 9.3.1 above.)
- 2 Press  **Option** to open the drafts submenu, then scroll  to **Delete All** and press  **Select**.
- 3 **Delete All?** is displayed. Press  **OK** to delete all draft messages. (Press  **Back** to return to the drafts submenu.)
 - **Waiting...** is displayed for a moment then **Deleted!** is displayed briefly, and the display returns to the **SMS** menu.

9.4 Settings



9.4.1 SMS Reception

Use this menu to turn SMS reception ON (the default) or OFF. Also use it to change the SMS box number (country dependent).

9.4.1.1 Turn SMS Reception ON/OFF







- 1 Press  in idle mode, scroll  to **SMS**, and press  **Select**.
- 2 Scroll  to **Settings** and press  **Select**; press  **Select** again to open the **SMS Reception** menu.
- 3 Scroll  to select **On** or **Off** and press  **Select**.
 - A confirmation tone will sound and the display will return to the **SMS Settings** menu.

9.4.1.2 Change the SMS Box Number (Country dependent)

- 1 Follow steps 1 and 2 above. Then, scroll  to **Change Box Nr** and press  **Select**.
- 2 Edit the box number and press  **OK**.
 - A confirmation tone will sound and the display will return to the **SMS Settings** menu.

9.4.2 SMS Centre

Use this menu to set the incoming and outgoing numbers for up to three SMS centres.

- 1 Press  in idle mode, scroll  to **SMS**, and press  **Select**.
- 2 Scroll  to **Settings** and press  **Select**. Scroll  to **SMS Centre** and  **Select**.

3 Scroll to select **SMS Centre 1**, **SMS Centre 2**, or **SMS Centre 3** and press **Select**.

4 Scroll to select **Outgoing Nr** or **Incoming Nr** and press **Select**.

5 Input the number and press **OK**.

- A confirmation tone will sound and the display will return to the previous screen so you can input the other number.
- When you have finished inputting both outgoing and incoming numbers, press **Back** to return to the **SMS Centre** menu.

9.4.3 Default Centre

Use this menu to select the default SMS center.

1 Press in idle mode, scroll to **SMS**, and press **Select**.

2 Scroll to **Settings** and press **Select**. Scroll to **Default Centre** and **Select**.

3 Scroll to select **SMS Centre 1**, **SMS Centre 2**, or **SMS Centre 3** and press **Select**.

- A confirmation tone will sound and the display will return to the **SMS Settings** menu.



10 Telephone answering machine (TAM)

Your phone features an answering machine that records unanswered calls when it is activated. The answering machine can store up to 59 messages. The maximum recording time is 3 minutes per message, or 30 minutes for all messages. The maximum length of an outgoing message is 1 minute. You can use the control keys on the base station to perform the basic functions of the answering machine such as message playback, deleting messages and adjustment of volume on the base station. For a description of each function of the control keys on the base station, please see "Overview of the base station" (section 2.4) for more details. You can also use the answering machine menu on the handset to access the answering machine functions. Those procedures are covered below. There is also a menu to set the answering machine options. The telephone answering machine is ON by default. To switch the answering machine between on and off, press on your base station. Alternatively, you may switch the answering machine on and off via your handset (see section 10.6.2).

10.1 Playing Messages

10.1.1 Playback of messages via handset



The answering machine message counter blinks when there are new messages and display the number of new messages. The first recorded message is played first via the loudspeaker. When all new messages have been played, the answering machine will stop and the message counter will stop blinking.

1 Press the  key in idle mode, scroll  to **Answer Machine**, and press  **Select**.

2 **Play** is highlighted. Press  **Select** to start playing new messages.

- The handset displays **New** and the number of new messages in the format **01/04**, where **01** is the number of the message being played and **04** is the number of new messages.
- If there are no new messages, the handset displays the number of old messages in the same format (however 'New' is not displayed.) and plays the old messages.

10.1.2 Functions available during playback

During playback, you can enable the following functions by pressing  **Menu**. Use  to scroll between the

functions and press  **Select** to confirm.

Repeat	Replay the current message
Next	Listen to the next message.
Previous	Listen to the previous message.
Delete	Delete the message currently playing.

10.2 Delete all messages





Warning

Deleted messages cannot be recovered.



Note

Unplayed messages will not be deleted.

1 Press the  key in idle mode, scroll  to **Answer Machine**, and press  **Select**.

2 Scroll  to **Delete All** and press  **Select**.





3 **Delete All?** is displayed on the screen. Press  **OK** to confirm deletion of all your messages.

- **Waiting...** is displayed while the messages are deleted; then, **Deleted** is displayed for 2 seconds, and the display returns to the **Answer Machine** menu.

10.3 Turn the Answering Machine On/Off

You can turn the answering machine on or off from the handset as follows.

1 Press the  key in idle mode, scroll  to **Answer Machine**, and press  **Select**.









- 2 Scroll  to **Answer On/Off** and press  **Select**.
- 3 Scroll  to select **On** or **Off** and press  **Select**.
 - A validation tone is emitted and the screen returns to **Answer Machine** menu.

10.4 Play, Record, or Delete an Outgoing Message

You can record a personalized message to be played when the answering machine picks up an incoming call.







Note

The maximum length of an outgoing message is 1 minute.

- 1 Press the  key in idle mode, scroll  to **Answer Machine**, and press  **Select**.
- 2 Scroll  to **Record OGM** and press  **Select**.
- 3 Scroll  to select **Answer & Rec.** or **Answer Only** and press  **Select**.
- 4 Scroll  to select **Play, Record Message**, or **Delete** and press  **Select**.
 - If **Play** is selected, the current outgoing message is played.
 - If **Record Message** is selected, a beep sounds and the handset starts automatically recording a message.
 - If **Delete** is selected and a personal outgoing message was previously recorded, **Deleted** is displayed. The predefined OGM is reinstated automatically.

10.5 Set the Answer mode

There are 2 answer modes available: Answer Only and Answer & Record. By default, the answer mode is Answer & Record, which lets your caller leave a message on the answering machine. This can be changed to Answer Only mode, which does not allow your caller to leave any messages on the answering machine.

- 1 Press the  key in idle mode, scroll  to **Answer Machine**, and press  **Select**.
- 2 Scroll  to **Answer Mode** and press  **Select**.
- 3 Scroll  to select **Answer & Rec.** or **Answer Only** and press  **Select**.
 - A validation tone is emitted and the screen returns to **Answer Machine** menu.

Note

Depending on the answer mode you have selected, the appropriate default outgoing message is played once the answering machine picks up an incoming call.

Tip









You can set the answering machine to play a personalized outgoing message. See 10.4 above.

10.6 Answering Machine Settings

10.6.1 Ring Delay

This is the number of rings before the answering machine answers and starts playing your greeting message. You can set the answering machine to start

playing your greeting message after 3 to 8 rings or the “Economy” option. The default ring delay is **Economy**.

- 1 Press the  key in idle mode, scroll  to **Answer Machine**, and press  **Select**.
- 2 Scroll  to **Settings** and press  **Select**.
- 3 **Ring Delay** is highlighted. Press  **Select**, then scroll  to select from **3 to 8** or **Economy**.
- 4 Press  **Select** to confirm.
 - A validation tone is emitted and the display returns to the **Settings** menu.

Note

If **Economy** is selected, the ring delay depends on the answering machine's condition.

- If there are new messages in the answering machine, it will pick up the line after 2 rings.
- If there are no new messages in the answering machine, it will pick up the line after 4 rings.
- Hence, if you want to check if you have any messages without incurring call charges, you can hang up the call after the 3rd ring.









10.6.2 Remote Access

You can check the messages on your answering machine by calling in from an outside line and entering the remote access code*. The keypad on the phone you use to dial in acts like the functions on your answering machine.

Note

This feature is deactivated by default.
* The remote access code (which is the same as your PIN code) prevents any unauthorised remote access of your answering machine.

10.6.2.1 Activate/Deactivate Remote Access

- 1 Press the  key in idle mode, scroll  to **Answer Machine**, and press  **Select**.
- 2 Scroll  to **Settings** and press  **Select**. Then, scroll  to **Remote Access** and press  **Select**.
- 3 Scroll  to select **Activate** or **Deactivate** and press  **Select**.
 - A validation tone is emitted and the screen returns to **Settings** menu.

10.6.2.2 Controlling the Answering Machine from an external call

- 1 From your external phone, dial home.
 - The answering machine answers and starts playing your greeting message.
- 2 Press # key and enter the remote access code (same as your PIN code).
 - If the access code is incorrect, an error tone will be emitted. Then enter the PIN code again. If the PIN code is still incorrect, the

answering machine will drop the line immediately.

- If the remote access code is correct, a short validation tone will be heard.

Note



Operation is cancelled if the PIN code is not entered within 8 seconds.

If the answering machine is off, the phone will enter into the remote access mode after 10 rings. A beep will then sound, prompting you to enter the PIN code. Enter the PIN (default is 0000) to activate the remote access feature. You can then turn ON the answering machine and play the recorded messages.

The following table indicates how to access the functions of the answering machine using the telephone keypad.

Key	Action
1	Go to previous message.
2	Play the message.
3	Skip to the next message.
6	Delete the playing message.
7	Turn on the answering machine.
8	Stop message playback.
9	Turn off the answering machine.









10.6.3 Handset Screening

When Handset call screening is set to **On**, you can press  **Screen** to start call screening for incoming messages. If you decide to pick up the call, press .









Once you pick up, the recording will stop automatically.

Note

If you have multiple handsets, only one handset can enable handset call screening for each call.

- 1 Press the  key in idle mode, scroll  to **Answer Machine**, and press  **Select**.
- 2 Scroll  to **Settings** and press  **Select**. Then, scroll  to **HS Screening** and press  **Select**.
- 3 Scroll  to select **On** or **Off** and press  **Select**.
 - A validation tone is emitted and the screen returns to **Settings** menu.

10.6.4 Setting the Outgoing Message Language

- 1 Press the  key in idle mode, scroll  to **Answer Machine**, and press  **Select**.
- 2 Scroll  to **Settings** and press  **Select**. Then, scroll  to **Voice Language** and press  **Select**.
- 3 Scroll  to select the language and press  **Select**.
 - A validation tone is emitted and the screen returns to **Settings** menu.

11 Technical data

Display

- Color LCD with backlight
- Selectable wallpaper
- Selectable colour theme

General telephone features

- Caller name & number identification
- 5 standard + 10 polyphonic ringer melodies
- Wideband synthesis for receiver and loudspeaker

Phonebook list, Redial list and Call log

- Phonebook list with 200 entries
- Redial list with 10 entries
- Call log with 50 entries

Battery

- 2 × AAA, 600mAh batteries

Radio specifications

- Frequency Band: 1880 - 1900Mhz
- Maximum output power: 250mW

Weight and dimensions

Base:

- 189.5 grams
- 77mm × 115mm × 131mm
(H × D × W)

Handset:

- 128.5 grams
- 162mm × 31.5mm × 48mm
(H × D × W)

Temperature range

- Operation: Between 0 and 35°C (32 to 95°F).
- Storage: Between -20 and 70°C (-4 to 158°F).

Relative humidity

- Operation: Up to 95% at 40°C
- Storage: Up to 95% at 40°C

12 Frequently asked questions

In this chapter, you will find the most frequently asked questions and answers about your phone.

12.1 Connection

The handset does not switch on!

- Charge the batteries: Put the handset on the base station to charge. After a few moments, the phone will switch on.
- You may have accidentally switched off the handset. In this case, press and hold  for at least 1 second to switch it on again (see section 5.1 - "Switch the handset off/on").

The handset does not charge!

- Check charger connections.

icon is not blinking during charge!

- Battery is full: There is no need to charge the battery.
- Bad battery contact: Adjust the handset slightly.
- Dirty contact: Clean the batteries contact with a cloth moistened with alcohol.

Communication is lost during a call!

- Charge the battery
- Move closer to the base station.

The phone is “Out of range”!

- Move closer to the base station.

12.2 Set-up

Searching... is displayed on handset and icon is blinking!

- Move closer to the base station.
- Make sure that your base station is on.
- Reset your unit and restart handset registration.

12.3 Sound

Handset does not ring!

Check that the **Ring Volume** is not set to no bars (Ringer Off), and make sure the  icon is not displayed on the screen (see section 6.2.1 - “Set the Ring Volume”).

Caller does not hear me!

Microphone may be muted: During a call, press .

There's no dialling tone!

- No power: Check the connections.
- Batteries are empty: Charge the batteries.
- Move closer to the base station.
- Wrong line cable used: Use the line cable provided.
- Line adaptor is required: Connect the line adaptor to the line cord.

Caller does not hear me clearly!

- Move closer to the base station.
- Move the base station at least one metre away from any electronic appliances.

Frequent noise interference on my radio or television!

- Move the base station as far away as possible from the electrical appliances.

12.4 Product behaviour

Keypad does not work!

- Unlock your keypad: Long press  in idle mode.

The handset warms up when making a long call and when it is on the base station!

- This is a normal behavior. The handset consumes energy while calling and charging.

The handset cannot be registered to the base station!

- Maximum number of handsets (5) has been reached. To register a new handset, unregister an existing handset.
- Remove and replace the handset batteries.
- Try again by disconnecting and connecting the base station power supply and follow the procedure to register a handset (see section 7.6).

Caller number is not displayed!

- Service is not activated: Check your subscription with Belgacom.

I cannot change the settings of my Phonemail!

- Operator Phonemail is managed by Belgacom and not the phone itself. Please contact Belgacom should you want to change the settings.

My handset keeps going into idle mode!

- If there are no key presses for 30 seconds, the handset will automatically return to idle mode. It will also return to idle mode automatically when you place the handset back on the base station (if auto hang-up feature is on).

Phonebook entry cannot be stored and Memory Full is displayed!

- Delete an entry to free memory before saving your contact again.

The PIN code is wrong!

- The default PIN is 0000.
- Reset the handset to revert to the default PIN code if it has been changed before (see “Reset Unit” - Section 7.8).

The answering machine does not record calls.

- Make sure the answering machine is connected to the power adaptor, and the power adaptor is plugged into mains supply which is switched on.
- Check if the answer machine is off, or Answer only mode is selected.
- Check to see if the answering machine is memory full. If so, delete some or all messages.
- Try switching off the power at the mains socket, and then turn it on again after 1 minute.

Unable to perform remote operation

- Make sure the remote access is on (see Section 10.6.2).
- Make sure you entered the correct remote access code.
- Use a touch-tone phone.

Note

If the above solutions do not help, remove the power from both the handset and the base. Wait for 1 minute and try again.

Cannot receive new SMS

- Check if SMS storage space is full, and delete old SMS.

- Make sure that your SMS settings are correct (see Section 9.4).
- In order to use SMS, you must subscribe to both SMS and Caller Line Identification (CLI) service. Contact Belgacom for more information.

Cannot send or receive new SMS

- Make sure that your SMS settings are correct (see Section 9.4).
- In order to use SMS, you must subscribe to both SMS and Caller Line Identification (CLI) service. Contact Belgacom for more information.
- Check whether another SMS-enabled phone is also on your line. If so, deactivate SMS reception on one of the devices.

13 Declaration of Conformity

We,

PCE

9, rue Maurice Trintignant

72081 Le Mans Cedex 9

France

Declare that the products Twist™ 619 are in compliance with ANNEX IV of the R&TTE-Directive 1999/5/EC and then with the following essential requirements:

Article 3.1 a : (protection of the health & the safety of the user)

Safety : EN 60950-1 (2006)

Article 3.1 b : (protection requirements with respect to electromagnetic compatibility)

EMC : ETSI EN 301 489-6 V1.2.1 (2002) & ETSI EN 301 489-1 V1.6.1 (2005)

Article 3.2 : (effective use of the radio spectrum)

Radio : EN 301 406 V1.5.1 (2003)

The presumption of conformity with the essential requirements regarding Council Directive 1999/5/EC is ensured.

Date : 01/07/2008 Le Mans



CE 0168

Product Quality Manager
Home Communication

14 INDEX

A

- Access phonebook 26
- Access Redial list 29
- Access the Call log 30
- Access the Call Return Service 47
- Activate/Deactivate loudspeaker mode 26
- Activate/Deactivate Remote Access 56
- Adjust earpiece or speaker volume 25
- Advanced settings 37
- Advanced Settings menu tree 19
- Answer a call 24
- Answer an external call during intercom 32
- Answer Machine menu tree 22
- Answering Machine Settings 55
- Auto Conference 38
- Auto hang-up 37

B

- Backlight timing 37
- Base station 12
- Batteries 14

C

- Call Barring 38
- Call Forward 43
- Call Forward when Busy 44
- Call Forward when Unanswered 45
- Call from redial list 23
- Call from the call log 23
- Call from the phonebook 23
- Call Return 47
- Call the Cancel Call Back Number 48
- Call using Direct Access Memory 24

- Cancel Call Back 47

- Change Call Forward Activation Codes 44
- Change Call Forward Deactivation Code 44
- Change Call Forward when Busy Activation Codes 45
- Change Call Forward when Busy Deactivation Code 45
- Change Call Forward when Unanswered Activation Codes 46
- Change Call Forward when Unanswered Deactivation Code 46
- Change Flash time 42
- Change PIN 40
- Change the Display Language 36
- Change the Handset Name 35
- Change the SMS Box Number 52
- Charge battery 15
- Clock and Alarm menu tree 18
- Clock and Alarm settings 33
- Color themes 36
- Connect the base station 13
- Contrast 37

D

- Deactivate/Activate Auto Hang-Up 37
- Default Centre 53
- Default PIN code 40
- Default settings 42
- Delete a call list entry 31
- Delete a Draft 52
- Delete a phonebook entry 28
- Delete a redial number 29
- Delete all call list entries 31

- Delete all Drafts 52
- Delete all messages 54
- Delete all phonebook entries 28
- Delete all redial numbers 30
- Delete all SMS Messages 51
- Delete an SMS Message 50
- Delete Phonemail 28
- Direct dialling 23
- Display icons and Messages 10
- Display languages 36
- Drafts 51

E

- Easy Call 37
- Edit a Draft 51
- End a call 24
- Establish a three-party conference call 32

F

- Flash time 42
- Forward an SMS Message 50
- Frequently asked questions 58
- Functions available during playback 54

G

- Getting started 13

H

- Handset name 35
- Handset Screening 57
- Handset Tones 35
- Handsfree answering 24

I

- Inbox 49
- Install battery 14
- Install your phone 14
- Intercom 31

K

- Key Beep 36
- Keypad lock/unlock 25

M

- Make a call 23
- Menu structure 16
- Modify a phonebook entry 27
- Mute/Unmute microphone 25

N

- Network Services 43
- Network Services menu tree 20

O

- Open a Draft 51
- Overview of the base station 12
- Overview of your phone 8

P

- Paging 33
- Personal settings 35
- Personal Settings menu tree 17
- Personalized message 55
- Phonebook menu tree 16
- Phonemail 28
- PIN 40
- Play, Record, or Delete an Outgoing Message 55
- Playback of messages via handset 54
- Playing Messages 54
- Power requirements 4
- Predialling 23

R

- Read SMS Messages 49
- Registration 40
- Remote Access 56
- Reply to an SMS Message 50

Reset Unit 41
Ring Delay 55
Ring tones 35
Ring Volume 35

S

Save a redial number 29
Save call list entry 31
Save the Number of an SMS Message 50
Select phonebook melody 27
Select the Color Theme 36
Select the Display Wallpaper 36
Send a Draft 51
Set a Call Barring number 39
Set Alarm 34
Set Alarm Tone 34
Set Call Barring Mode 39
Set Call Return Service Number 47
Set Date and Time 33
Set Date Format 34
Set Easy Call number 38
Set Easy Call to On or Off 38
Set First Ring Detection 42
Set the Answer mode 55
Set the Backlight Time 37
Set the Cancel Call Back Number 48
Set the Display Contrast 37
Set the Ring Tones 35
Set the Ring Volume 35
Set Time Format 33
Set Voice Mail Number 47
Setting the Outgoing Message
 Language 57
Short Message Service 48
SMS 48
SMS box number 52
SMS Centre 52
SMS Drafts 51
SMS Inbox 49

SMS menu tree 21
SMS Reception 52
SMS Settings 52
Store a contact in the phonebook 26
Switch between an internal and external
 call 32
Switch the handset off/on 25

T

Technical data 58
Telephone answering machine 53
Text or number entry 25
The call log 30
Transfer an external call 32
Turn the Answering Machine On/Off 54

U

Unregister 41
Using the Call log 30
Using the Intercom 31
Using the Redial list 29
Using your phone 23
Using your Phonebook 26

V

Voice Mail 46

W

Wallpaper images 36
What's in the box 7
Write and Send an SMS 48

X

XHD Sound 39

Y

Your phone 7